

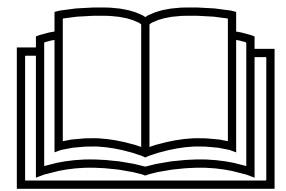

FG Wilson Generator Set Operator & Maintenance Instruction Manual



This manual has been designed as a guide to operators to aid in starting, stopping and otherwise operating the generator set.



ORIGINAL INSTRUCTIONS

CONTENTS

1. INTRODUCTION	6
2. SAFETY	7
2.1 General	7
2.1.1 Emergency Stop Button.....	7
2.2 Personal Protective Equipment	7
2.3 General Hazard Information	8
2.3.1 Pressurized Air and Water.....	8
2.3.2 Containing Fluid Spillage	8
2.3.3 Lines, Tubes and Hoses.....	8
2.3.4 Disposal of Waste.....	9
2.4 Fire and Explosion	9
2.4.1 Fire Extinguisher	9
2.5 Exhaust Gases	10
2.6 Mechanical.....	10
2.7 Chemical	10
2.7.1 Coolant.....	10
2.7.2 Oils.....	10
2.7.3 Batteries	10
2.8 Noise	11
2.9 Electrical	11
2.9.1 Neutral-Earth Link (NEL).....	11
2.9.2 Generator Isolating.....	11
2.10 First Aid For Electric Shock	12
2.11 Hazard Label Legend	14
3. GENERAL DESCRIPTION	16
3.1 Typical Rating Plate	16
3.2 Generator set Description	17
3.3 Power Factor	18
4. INSTALLATION, HANDLING AND STORAGE	19
4.1 General.....	19
4.2 Outdoor Installation	20
4.2.1 Positioning of Walk-in Containers	21
4.2.2 Concrete Plinth.....	21
4.2.3 Installation Location.....	21
4.2.4 Exhaust Discharge.....	21
4.3 Moving the Generator set.....	22
4.3.1 Approved Lifting Methods for ISO Walk-in Containers.....	26
4.3.2 Approved Lifting Methods for Non-ISO Walk-in Containers	26

4.4	Foundations and Vibration Isolation.....	27
4.4.1	Foundation	27
4.4.2	Vibration Isolation	27
4.5	Storage.....	28
4.5.1	Engine Storage	28
4.5.3	Battery Storage.....	28
5.	CONTROL SYSTEM DESCRIPTION AND TROUBLE SHOOTING	29
5.1	Control System Description	29
5.1.1	Pre-Start Checks (applicable to all control systems).....	29
5.2	PowerWizard 1.1, 1.1+ & 2.1 (Quickstart).....	31
5.2.1	General Information	31
5.2.2	PowerWizard Control Module Description	31
5.2.3	Basic Operation.....	32
5.2.4	Fault / Alarm Reset Process.....	33
5.2.5	User Interface Overview	33
5.2.6	Alarm Log and Resetting	35
5.2.7	Security	36
5.2.8	Real Time Clock Programming (PowerWizard 2.1)	37
5.2.9	Fuel Transfer (PowerWizard 2.1)	37
5.2.10	Additional Features Available.....	37
5.2.11	Trouble Shooting Guide for PowerWizard	38
5.3	PowerWizard 2.1+ / 4.1.....	39
5.3.1	PowerWizard 2.1+ Control Module Description.....	39
5.3.2	PowerWizard 4.1 Control Module Description	41
5.3.3	Alarm Log and Resetting	42
5.3.4	Security	43
5.3.5	Real Time Clock Programming.....	44
5.3.6	Fuel Transfer	44
5.3.7	Additional Features Available	44
5.3.8	Trouble Shooting Guide for PowerWizard.....	45
5.4	DCP-10 & DCP-20.....	46
5.4.1	General Information	46
5.4.2	DCP Control Module Description	46
5.4.3	Basic Operation.....	47
5.4.4	Fault / Alarm Reset Process - DCP-10	48
5.4.5	Fault / Alarm Reset Process - DCP-20	48
5.4.6	User Interface Overview	48
5.5	DeepSea Controller	51
5.5.1	Description	51
5.5.1	Alarm Icons.....	52
5.5.2	Electrical Trip Alarm Icons	52
5.5.3	Stop/Reset Mode.....	52
5.5.4	Fault Finding.....	53

5.6	Control System Options and Upgrades	55
5.6.1	Battery Trickle / Auto Boost Chargers	55
5.6.2	Heaters	55
5.6.3	Electric Fuel Transfer Pumps.....	55
5.6.4	Meters / Gauges.....	56
5.6.5	Speed / Voltage Control	56
5.6.6	Alarm Signalling	56
5.6.7	Automatic Preheat Control	56
5.6.8	Remote Annunciator Panels	56
6.	OPERATION	57
6.1	Priming Procedure for 1100 Series	57
6.1.1	Products fitted with the small Perkins pre-filter / water separator	57
6.1.2	Perkins 1506, 2206, 2506, 2806 Engines fitted with pre-filter / water separator.....	58
6.1.3	Products fitted with the Racor Pre-Filter / Water Separator (Option).....	59
6.1.3	Troubleshooting	60
6.1.4	Starting with Jump Start Cables	61
6.2	Fuel Conservation.....	61
6.3	Cold Weather Operation	62
6.3.1	Hints for Cold Weather Operation	62
6.3.2	Viscosity of the Engine Lubrication Oil.....	62
6.3.3	Recommendations for the Coolant.....	62
7.	LOAD TRANSFER PANELS	63
7.1	Engine Interface Module Description (where fitted).....	64
7.2	Output Circuit Breaker Description	64
8.	ELECTRONIC ENGINE FAULT DETECTION FLASH CODES	65
9.	MAINTENANCE	66
9.1	Battery Maintenance	66
9.1.1	Battery Removal and Fitting.....	67
9.1.2	Battery Fluid Levels.....	67
9.2	Preventative Maintenance Interval Schedule	68
9.3	Alternator Preventative Maintenance.....	68
9.4	Engine Preventative Maintenance	68
9.5	Welding on or near Generator Sets.....	69
9.6	Decommissioning, Dismantling and Disposal	69

1. INTRODUCTION

Thank you for choosing our company to supply your electrical power needs. In line with our policy of continuous product improvement, we reserve the right to change the information contained within this manual without notice.

This Operator Instruction Manual has been designed to help you operate and maintain your electrical generator set correctly. We recommend that the operator should take the time to read this manual. Certain tasks may require work to be completed by specifically trained technicians, an operator should only attempt a task detailed for an operator to complete.

This generator set is one of a family of heavy duty industrial generator sets designed to be ready to run when it arrives. Years of diesel generator set experience has gone into the set to produce a quality source of electrical power that is efficient and reliable.

Always ensure that maintenance, adjustments and repairs are done by personnel who are authorised to do the work and have been properly trained. Maintenance and repairs should also be carried out at regular intervals using genuine parts, this will prolong the life of the generator set. The manufacturer is not liable for any defects or claims due to the user's improper installation, maintenance or use, or for any products which have been modified in any way from the state in which they were sold. All generator sets should only be operated by those required to do so and therefore be safely kept away from non authorised use.

Some photographs or illustrations in this manual show details or attachments that may be different from your generator set. These images are for illustrative purposes only. If you have any questions regarding your generator set, please contact your local Dealer for the latest available information.

Every generator set is uniquely defined by a model number and serial number indicated on a rating plate generally affixed to the alternator housing (See Section 3.1). This information is required when ordering spare parts or when service or warranty work is required.

2. SAFETY

2.1 General

The generator set is designed to be safe when used in the correct manner. Responsibility for safety, however, rests with the personnel who use the set. Before performing any procedure or operating technique, it is the user's responsibility to ensure that it is safe to do so.

Warning:

- ⚠ **Read and understand all safety precautions and warnings before operating the generator set.**
- ⚠ **Failure to follow the instructions, procedures and safety precautions in this manual may increase the possibility of accidents and injuries.**
- ⚠ **Never start the generator set unless it is safe to do so.**
- ⚠ **Do not attempt to operate the generator set with a known unsafe condition.**
- ⚠ **If the generator set is unsafe, fit danger notices and disconnect the battery negative (-) lead so that it cannot be started until the condition is corrected.**
- ⚠ **Ensure the generator set is protected from any unauthorised use, use signs were appropriate.**
- ⚠ **Disconnect the battery negative (-) lead prior to attempting installation, repairs or cleaning on the generator set.**
- ⚠ **Install and operate this generator set only in full compliance with relevant National, Local, or Federal Codes, Standards or other requirements.**

2.1.1 Emergency Stop Button

The emergency stop button is in the OUT position for normal engine operation. Push the emergency stop button. The engine will not start when the button is locked. Turn the button clockwise in order to reset.

Warning

- ⚠ **Familiarise yourself with the location of the Emergency Stop Button. Emergency shutoff controls are for EMERGENCY use ONLY.**
- ⚠ **DO NOT use emergency shutoff devices or controls for normal stopping procedure.**
- ⚠ **Do not start the engine until the problem necessitating the emergency stop has been located and corrected.**



2.2 Personal Protective Equipment



Figure 2.1 – Typical PPE to be worn by an Operator

- Appropriate PPE should always be worn whilst working in and around the generator set. Wear a hard hat, protective glasses, gloves and other protective equipment, as required by generator set location.
- When work is performed around an engine that is operating, wear protective devices for ears in order to help prevent damage to hearing.
- Do not wear loose clothing or jewellery that can snag on controls or on other parts of the engine.

- Ensure that all protective guards and all covers are secured in place on the engine.
- Never put maintenance fluids into glass containers. Glass containers can break.
- Use all cleaning solutions with care.
- Report all necessary repairs.

Unless other instructions are provided, perform the maintenance under the following conditions:

- The engine is stopped. Ensure that the engine cannot be started.
- Disconnect the batteries when maintenance is performed or when the electrical system is serviced. Disconnect the battery ground leads. Tape the leads in order to help prevent sparks.
- Do not attempt any repairs that are not understood. Use the proper tools. Replace any equipment that is damaged or repair the equipment.

2.3 General Hazard Information

2.3.1 Pressurized Air and Water

⚠ Do not use pressurized water near electrical components or near component's bearings

Pressurized air and/or water (not recommended) can cause debris and/or hot water to be blown out which could result in personal injury.

When pressurized air is used, wear protective clothing, protective shoes and eye protection. Eye protection includes goggles or a protective face shield.

The maximum air pressure for cleaning purposes must be reduced to 205 kPa (30 psi) when the air nozzle is deadheaded and used with effective chip guarding (if applicable) and personal protective equipment. The maximum water pressure for cleaning purposes must be below 275 kPa (40 psi). Always wear eye protection for cleaning the cooling system.

Do not touch any part of an operating engine. Allow the engine to cool before any maintenance is performed on the engine. Relieve all pressure in the air system, in the hydraulic system, in the lubrication system, in the fuel system, or in the cooling system before any lines, fittings or related items are disconnected.

2.3.2 Containing Fluid Spillage

Care must be taken to ensure that fluids are contained during inspection, maintenance, testing, adjusting and repair of the product. Be prepared to collect the fluid with suitable containers before opening any compartment or disassembling any component containing fluids.

Note:

- If fluid containment is incorporated into the baseframe it must be inspected at regular intervals. Any liquids present (fuel, oil, coolant, rainwater or condensation) should be drained out and disposed of in accordance with local regulations and mandates.

2.3.3 Lines, Tubes and Hoses

Do not bend or strike lines. Do not install lines, tubes, or hoses that are damaged.

Inspect all lines, tubes, and hoses carefully. Do not use bare hands to check for leaks. Organise with your local Dealer repair of any fuel lines, oil lines, tubes, or hoses that are loose or damaged

Check for the following conditions:

- End fittings that are damaged or leaking
- Outer covering that is chafed or cut
- Wire that is exposed in reinforced hose
- Outer covering that is ballooning
- Flexible part of the hose that is kinked or crushed
- Armoring that is embedded in the outer covering

Ensure that all of the clamps, the guards and the heat shields are installed correctly. Correct installation of these components will help to prevent these effects: vibration, rubbing against other parts and excessive heat during operation.

2.3.4 Disposal of Waste

Improper disposal of waste can threaten the environment. Potentially harmful fluids should be disposed of according to local regulations. Always use leakproof containers when you drain fluids. Do not pour waste onto the ground, down a drain, or into any source of water.



2.4 Fire and Explosion

All fuels, most lubricants, and some coolant mixtures are flammable. Flammable fluids that are leaking or spilled onto hot surfaces or onto electrical components can cause a fire. Fire may cause personal injury and property damage.

Determine whether the engine will be operated in an environment that allows combustible gases to be drawn into the air inlet system. These gases could cause the engine to overspeed. Personal injury, property damage, or engine damage could result. If the application involves the presence of combustible gases, consult your local Dealer for additional information about suitable protection devices.

Do not allow any flammable materials to accumulate on the engine. Store fuels and lubricants in properly marked containers away from unauthorized persons. Store oily rags and any flammable materials in protective containers. Do not smoke in areas that are used for storing flammable materials.

Wiring must be kept in good condition, all electrical wires must be properly routed and securely attached. Check all electrical wires daily, seek appropriate maintenance from your local Dealer for any wires that are loose or frayed, before you operate the engine.

Arcing or sparking could cause a fire. Secure connections, recommended wiring and properly maintained battery cables will help to prevent arcing or sparking.

Never check the battery charge by placing a metal object across the terminal posts. Use a voltmeter or a hydrometer.

The batteries must be kept clean, the covers (if equipped) must be kept on the cells. Use the recommended cables, connections, and battery box covers (where fitted) when the generator set is operated.

Warning

- ⚠ **Do not charge a frozen battery, this may cause an explosion.**
- ⚠ **Ensure the generator set room is properly ventilated.**
- ⚠ **Keep the room, the floor and the generator set clean. When spills of fuel, oil, battery electrolyte or coolant occur, they should be cleaned up immediately.**
- ⚠ **Never store flammable liquids near the engine.**
- ⚠ **Store oily rags in covered metal containers.**
- ⚠ **Do not smoke or allow sparks, flames or other sources of ignition around fuel or batteries. Fuel vapours are explosive. Hydrogen gas generated by charging batteries is also explosive.**
- ⚠ **Avoid refilling the fuel tank while the engine is running.**
- ⚠ **Do not attempt to operate the generator set with any known leaks in the fuel system.**
- ⚠ **Do not use aerosol types of starting aids such as ether. Using these types of items could result in an explosion and personal injury.**

2.4.1 Fire Extinguisher

Fuels and fumes associated with generator sets can be flammable and potentially explosive. Proper care in handling these materials can dramatically limit the risk of fire or explosion. However, safety dictates that fully charged BC and ABC fire extinguishers are kept on hand. Personnel must be familiar with the operation of the fire extinguisher. Inspect the fire extinguisher and service the fire extinguisher regularly. Obey the recommendations on the instruction plate.



2.5 Exhaust Gases

Always start and operate the engine in a well-ventilated area. If the engine is in an enclosed area, vent the engine exhaust to the outside.

Warning

- ⚠ **Engine exhaust contains products of combustion which may be harmful to your health.**

2.6 Mechanical

The generator set is designed with guards for protection from moving parts. Care must still be taken to protect personnel and equipment from other mechanical hazards when working around the generator set.

Warning:

- ⚠ **Do not attempt to operate the generator set with safety guards removed. While the generator set is running do not attempt to reach under or around the guards for any reason.**
- ⚠ **Keep hands, arms, long hair, loose clothing and jewellery away from pulleys, belts and other moving parts. Some moving parts can not be seen clearly when the set is running.**
- ⚠ **Keep access doors on enclosures, if equipped, closed and locked when not required to be open.**
- ⚠ **Avoid contact with hot oil, hot coolant, hot exhaust gases, hot surfaces, sharp edges and corners.**
- ⚠ **Wear protective clothing including gloves and hat when working around the generator set.**

2.7 Chemical

Fuels, oils, coolants, lubricants and battery electrolyte used in this generator set are typical of the industry. However, they can be hazardous to personnel if not treated properly. The disposal of fuels, oils, coolants, lubricants, battery electrolyte and batteries should be carried out in accordance with local government laws and regulations.

2.7.1 Coolant

When the engine is at operating temperature, the engine coolant is hot. The coolant is also under pressure. The radiator and all hoses to the heaters or to the engine contain hot coolant. Any contact with hot coolant or with steam can cause severe burns. Allow cooling system components to cool before the cooling system is drained. Cooling system conditioner contains alkali. Alkali can cause personal injury. Do not allow alkali to contact the skin, the eyes, or the mouth.

2.7.2 Oils

Hot oil and hot lubricating components can cause personal injury. Do not allow hot oil to contact the skin. Also, do not allow hot components to contact the skin.

2.7.3 Batteries

Electrolyte is an acid. Electrolyte can cause personal injury. Do not allow electrolyte to contact the skin or the eyes. Always wear protective glasses for servicing batteries. Wash hands after touching the batteries and connectors. Use of gloves is recommended.

Warning:

- ⚠ **Do not swallow or have skin contact with fuel, oil, coolant, lubricants or battery electrolyte. If swallowed, seek medical treatment immediately. Do not induce vomiting if fuel is swallowed. For skin contact, wash with soap and water.**
- ⚠ **Do not wear clothing that has been contaminated by fuel or lube oil.**
- ⚠ **It is recommended to check the electrolyte level in accessible batteries every 500 hours.**

2.8 Noise

Sound levels will vary depending on the configuration of the generator set and the final installation of the generator set.

Refer to the following for factors that influence the level of exposure:

- The characteristics of the area around the generator set
- Gaps below generator set base and installation surface or plinth.
- Other sources of noise
- The number of machines and other adjacent processes
- The length of time of exposure to the noise

This information will enable the user of the machine to evaluate the hazard and the risk.

Warning:

- ⚠ **Prolonged exposure to noise levels above 80 dBA is hazardous to hearing.**
- ⚠ **Ear protection must be worn when operating or working around an operating generator set.**

2.9 Electrical

Warning

- ⚠ **Before the generator set is operated please consult your local dealer to establish whether an NEL has been fitted. As more than one NEL per site may be unsafe, it is important to establish whether one has already been installed on site.**

2.9.1 Neutral-Earth Link (NEL)

Depending on the specific product installation, a Neutral-Earth Link may be required on your generator set. Your local dealer or qualified electrical personnel should be consulted to confirm specific earthing requirements for the generator set installation, and to ensure that local wiring regulations are met.

Safe and efficient operation of electrical equipment can be achieved only if the equipment is correctly operated and maintained.

Warning:

- ⚠ **Ensure the generator set, including a mobile set, is effectively grounded/earthed prior to operation.**
- ⚠ **Do not touch electrically energised parts of the generator set and/or interconnecting cables or conductors with any part of the body or with any non insulated conductive object.**
- ⚠ **Use only Class BC or Class ABC extinguishers on electrical fires.**
- ⚠ **For generator sets with external socket outlets only – Residual Current Device (RCD) protection on socket outlets, where fitted, is designed to operate within a TN earthing system. Ensure local wiring regulations are met prior to generator set operation and that all equipment connected via the generator set sockets, including plugs and electrical cables, are of the correct specification and are known to be in a safe and undamaged condition.**

2.9.2 Generator Isolating

When you service or repair an electric power generation set, follow the procedure below:

1. Stop the engine.
2. Isolate the battery with the battery isolator provided. Attach a "DO NOT OPERATE" or similar warning tag to the engine prime mover starting circuit. Disconnect the engine starting circuit.
3. Disconnect the generator from the distribution system.
4. Lock out the circuit breaker. Attach a "DO NOT OPERATE" or similar warning tag to the circuit breaker. Refer to the electrical diagram. Verify that all points of possible reverse power flow have been locked out.
5. For the following circuitry, open miniature circuit breakers: power / sensing / control
6. Attach a "DO NOT OPERATE" or similar warning tag to the generator excitation controls.
7. Remove the cover of the generator's terminal box.
8. Use an audio/visual proximity tester to verify that the generator is de-energized. This tester must be insulated for the proper voltage rating. Follow all guidelines to verify that the tester is operational.
9. Determine that the generator is in a de-energized condition. Add ground straps to the conductors or terminals. During the entire work period, these ground straps must remain connected to the conductors and to the terminals.

2.10 First Aid For Electric Shock

Warning:

- ⚠ **Do not touch the victim's skin with bare hands until the source of electricity has been turned off.**
- ⚠ **Switch off the power, if possible.**
- ⚠ **Otherwise pull the plug or pull the cable away from the victim.**
- ⚠ **If this is not possible, stand on dry insulating material and pull the victim clear of the conductor, preferably using insulated material such as dry wood.**
- ⚠ **If victim is breathing, turn the victim into the recovery position.**
- ⚠ **If victim is unconscious, perform resuscitation as required:**

OPEN THE AIRWAY:

10. Tilt the victim's head back and lift the chin upwards.
11. Remove objects from the mouth or throat (including false teeth, tobacco or chewing gum).

BREATHING:

1. Check that the victim is breathing by looking, listening and feeling for the breath.



CIRCULATION:

1. Check for pulse in the victim's neck or wrist.

IF NO BREATHING BUT PULSE IS PRESENT:

1. Pinch the victim's nose firmly.
2. Take a deep breath and seal your lips around the victim's lips.
3. Blow slowly into the mouth watching for the chest to rise. Let the chest fall completely. Give breaths at a rate of 10 per minute.
4. If the victim must be left to get help, give 10 breaths first and then return quickly and continue.
5. Check for pulse after every 10 breaths.
6. When breathing restarts, place the victim into the recovery position described later in this section.

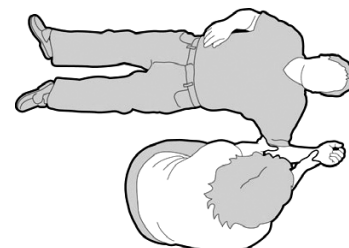

IF NO BREATHING AND NO PULSE:

1. Call or telephone for medical help.
2. Give two breaths and start chest compression as follows:
3. Place heel of hand 2 fingers breadth above ribcage/breastbone junction.
4. Place other hand on top and interlock fingers.
5. Keeping arms straight, press down 4–5 cm (1.5–2 inch) 30 times at a rate of 100 per minute. There should be equal timing between chest compression and release.
6. Repeat cycle (2 breaths, 30 compressions) until medical help takes over.
7. If condition improves, confirm pulse and continue with breaths. Check for pulse after every 10 breaths.
8. When breathing restarts, place the victim into the recovery position.



WARNING

- ⚠ **Do not apply pressure over the ribs, lower tip of the victim's breastbone or the abdomen.**

RECOVERY POSITION:

1. Turn the victim onto the side.
2. Keep the head tilted with the jaw forward to maintain the open airway.
3. Make sure the victim cannot roll forwards or backwards.
4. Check for breathing and pulse regularly. If either stops, proceed as above.

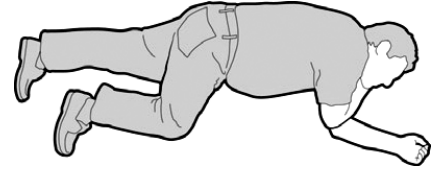
**Warning:**

- ⚠ **Do not give liquids until victim is conscious.**

2.11 Hazard Label Legend

Ensure that all of the safety messages are legible. Clean the safety messages or replace them if the words cannot be read or if the illustrations are not visible. Use a cloth, water and soap to clean the safety messages. Do not use solvents, gasoline, or other harsh chemicals as these could loosen the adhesive that secures the safety messages. Safety messages that are loosened could drop off the engine. Replace any safety message that is damaged or missing. If a safety message is attached to a part of the engine that is replaced, install a new safety message on the replacement part. Your local Dealer can provide new safety messages.

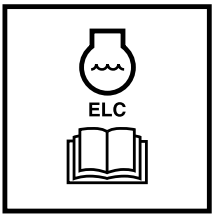

Extended Life Coolant

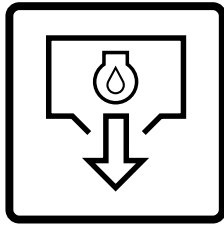

Oil Drain

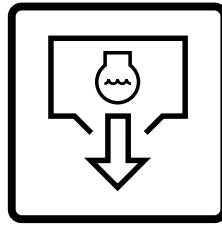

Coolant Drain



Diesel Fuel Fill



Remote Fuel Fill



Remote Fuel Fill Control



Hot Fluid Under Pressure



Warning Auto Start



Electric Electrocution

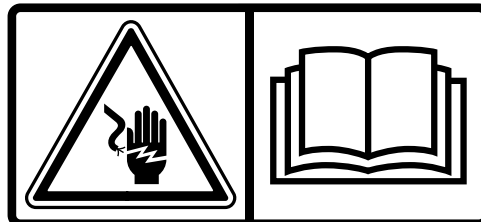

Electrical Shock Warning

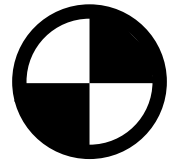

Centre of Gravity



Do Not Touch
Hot Surface



Warning
Crush Falling Object



Lift / Drag Point Symbol

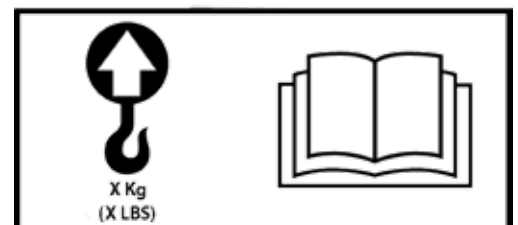

Single Point Lift is Rated at 'X' kg



Warning -
Read the manual

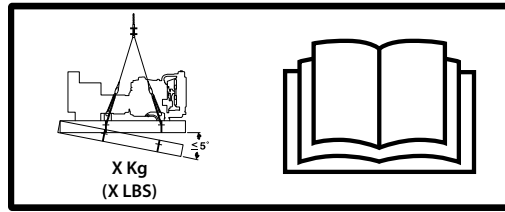

Four Point Lift is Rated at 'X' kg

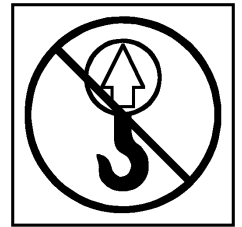

Do Not Lift Symbol



No Naked Flames



Battery Acid



Explosive Gas



Do NOT Powerwash



Take note of operating
instructions

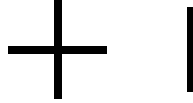

Positive & Negative
Electric Terminals

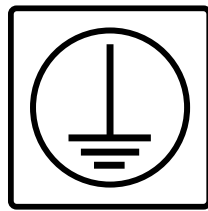

Earth

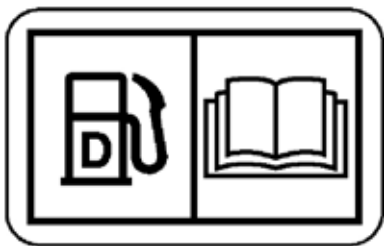

Desel Fuel -
Read the manual

3. GENERAL DESCRIPTION

This generator set has been designed as a complete package to provide superior performance and reliability.

Each generator set is provided with a Rating Plate generally affixed to the alternator housing / panel enclosure. This label contains the information needed to identify the generator set and its operating characteristics. This information includes, but is not limited to, the model and serial numbers, output characteristics such as voltage, phase and frequency, output rating in kVA and kW and rating type (basis of the rating). The model and serial numbers uniquely identify the generator set.

The diesel engine powering the generator set has been chosen for its reliability and the fact that it has been specifically designed for powering generator sets. The engine is of the heavy duty industrial type with 4 stroke compression ignition and is fitted with all accessories to provide a reliable power supply.

The engine electrical system is either 12 or 24 volts DC depending on the size of the set.

The engine cooling system comprises of a radiator, a high capacity pusher fan and a thermostat. The main AC alternator has its own internal fan to cool the alternator components.

The output electrical power is produced by an alternator fine tuned to the output of this generator set.

The engine and alternator are coupled together and mounted on a heavy duty steel base frame. The base frame incorporates an integrated or polyethylene fuel tank except for the largest sets (approximately 1,000 kVA and above).

The generator set is fitted with vibration isolators which are designed to reduce engine vibration being transmitted to the foundation on which the generator set is mounted. These isolators are fitted between the engine/alternator feet and the base frame. Alternatively, on 4008, 4012 and 4016 powered models the engine/alternator is rigidly mounted on the base frame and the vibration isolators are supplied loose to be fitted between the base frame and the foundation.

An exhaust silencer is provided loose for installation with the generator sets. The silencer and exhaust system reduce the noise emission from the engine and can direct exhaust gases to safe outlets.

One of several types of control systems and panels is fitted to control the operation and output of the generator set and to protect the set from possible malfunctions. Section 5 of this manual provides detailed information on these systems and will aid in identification of the control system fitted on the generator set.

To protect the alternator, a suitably rated circuit breaker selected for the generator set model and output rating is supplied mounted in a steel enclosure.

3.1 Typical Rating Plate

MANUFACTURED IN THE UNITED KINGDOM	
GENERATING SET ISO 8528	
MANUFACTURER	
MODEL	
SERIAL NUMBER	XXXXXXXXXXXXXXXXXX
SALES ORDER REF.	XXXXXX/XX
YEAR OF MANUFACTURE	2010
AMBIENT TEMP	25 °C
RATED POWER	
STANDBY	88.0 kVA 70.4 kW
PRIME	80.0 kVA 64.0 kW
RATED VOLTAGE	400/230 V
PHASE	3
RATED POWER FACTOR	0.80 COS ϕ
RATED FREQUENCY	50 Hz
RATED CURRENT - STANDBY	127 A
RATED CURRENT - PRIME	115 A
RATED RPM	1500 rpm
ALTITUDE	152.4 m
ALTERNATOR CONNECTION	S-STAR
ISO8528 - 3 RATING	PR 500H TL0.875
ALTERNATOR ENCLOSURE	23 IP
INSULATING CLASS	H
EXCITATION VLOTAGE	29 V
EXCITATION CURRENT	2 A
AVR	R438C
MASS	1463 kg

<ol style="list-style-type: none"> 1. Unique Generator set Number 2. Rated Ambient Temperature 3. Voltage Output of Generator set 4. Rated Altitude above Sea Level 5. Relates to AC Alternator 6. Ambient Temperature Information 	<ol style="list-style-type: none"> 1. 2. 3. 4. 5. 6.
--	--

This generator set is designed to operate in ambient temperatures up to 50 deg C and at higher altitudes
Please consult Dealer / Helpdesk for outputs available

Figure 3.1 – Description of Typical Rating Plate

3.2 Generator set Description

- 1. Radiator
 - 2. Radiator Fill
 - 3. Battery Charging Alternator
 - 4. Exhaust
 - 5. Turbo
 - 6. Oil Filter*
 - 7. Air Filter
 - 8. Alternator
 - 9. Emergency Stop Pushbutton
 - 10. Control Panel
 - 11. Circuit Breaker
 - 12. Base Frame
 - 13. Cable Entry
 - 14. Starter Motor
 - 15. Battery
 - 16. Fuel Fill*
 - 17. Lifting Points
 - 18. Jacket Water Heater
 - 19. Anti Vibration Mounts*
 - 20. Drag Points
 - 21. Fan Guards
- * = Opposite side

⚠ Generator sets contain moving parts and hot surfaces. Wear the appropriate PPE as required.

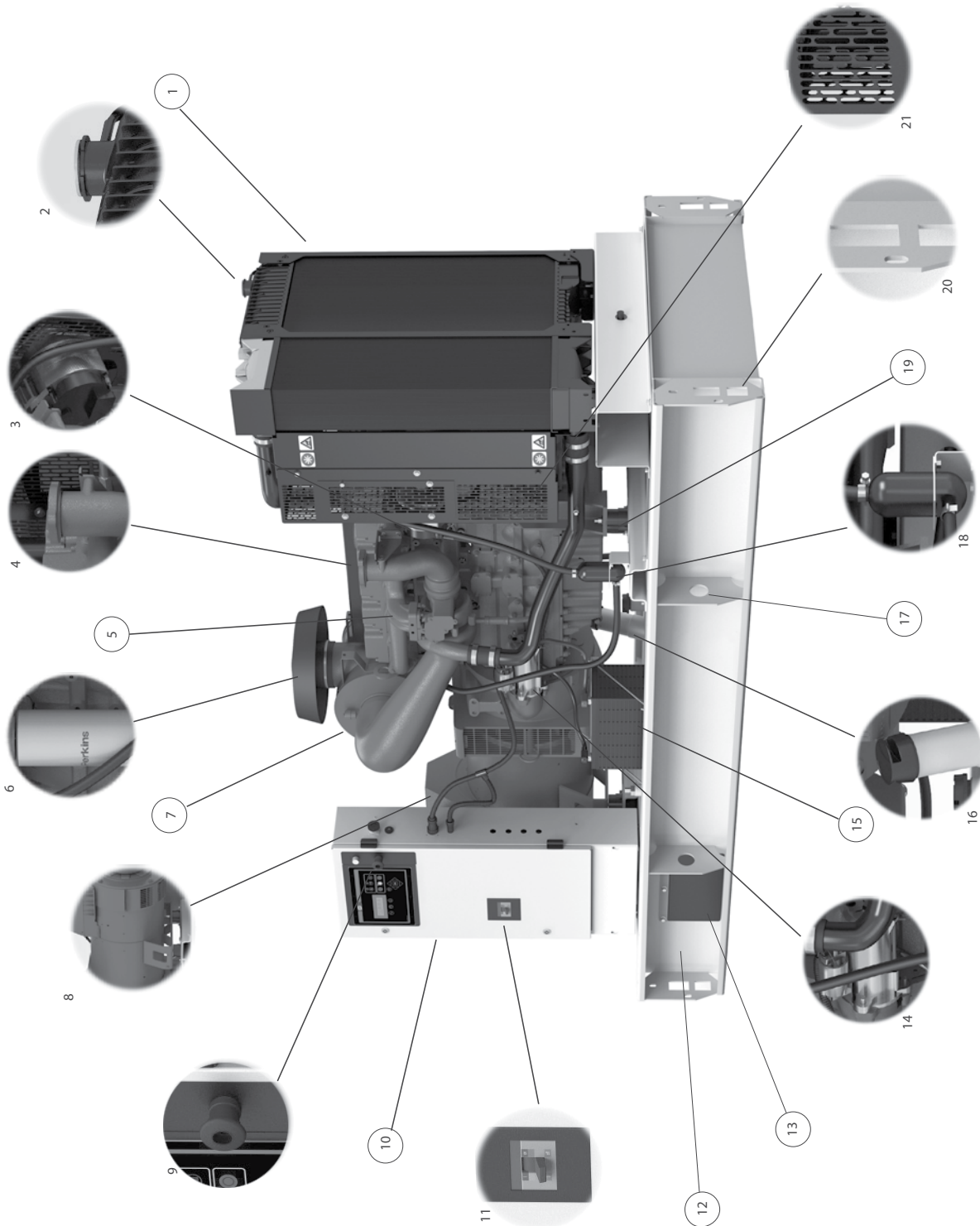

Figure 3.2 – Typical Generator set Description (this may differ from the Generator set you have received)

3.3 Power Factor

Power factor (PF) is the ratio of real power to apparent power. The real power is also known as the active power, or kW. The apparent power is also called kVA. Real power (kW) is the mechanical power output of the engine converted to electrical energy, consumed by the load. The apparent power (kVA) is the total power that is produced by the generator. Power factor can be calculated by using the following formula:

- $PF = kW / kVA$,
- kW – kilowatts (real power)
- kVA – Kilo-Volt-Ampere (apparent power)
- kVAR – kilo-Volt-Ampere (reactive power)

Note:

The generator does NOT control power factor. Power factor is determined by the load.

In most applications, loads such as electric motors, solid-state controls, and transformers determine the power factor of the system. Induction motors usually have a power factor that is no larger than 0.8. Incandescent lighting is a resistive load of about 1.0 power factor, or unity. Solid-state controls, variable frequency drives (VFD), variable speed drives (VSD), and control systems Uninterruptible Power Supplies (UPS) can operate at any power factor, leading, or lagging. In this case, the power factor can be between 0.4 and 1.0.

The power factor of a system may be determined by a measurement or by calculation and is displayed on the control panel.

4. INSTALLATION, HANDLING AND STORAGE

4.1 General

This section discusses factors important in the effective and safe installation of the generator set.

Selecting a location for the generator set can be the most important part of any installation procedure. The following factors are important in determining the location:

- Adequate ventilation.

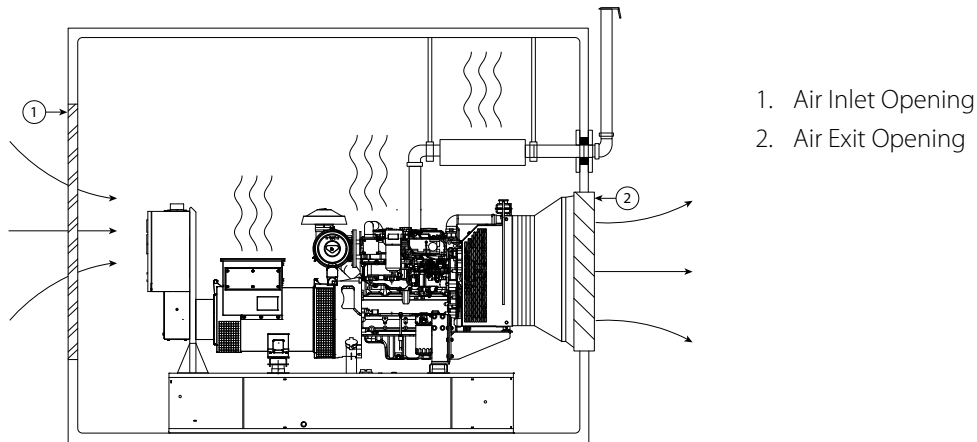

Figure 4.1 – Typical installation showing generator set ventilation

- Protection from the elements such as rain, snow, sleet, wind driven precipitation, flood water, direct sunlight, freezing temperatures or excessive heat.
- Protection from exposure to airborne contaminants such as abrasive or conductive dust, lint, smoke, oil mist, vapours, engine exhaust fumes or other contaminants.
- Protection from impact from falling objects such as trees or poles, or from motor vehicles or lift trucks.
- Clearance around the generator set for cooling and access for service: at least 1 metre (3ft 3in) around the set and at least 2 metres (6ft 6in) headroom above the set.
- Access to move the entire generator set into the room. Air inlet and outlet vents can often be made removable to provide an access point.
- Limited access to unauthorised personnel.

If it is necessary to locate the generator set outside of the building, the generator set should be enclosed in a weatherproof canopy or container-type housing which is available for all sets.

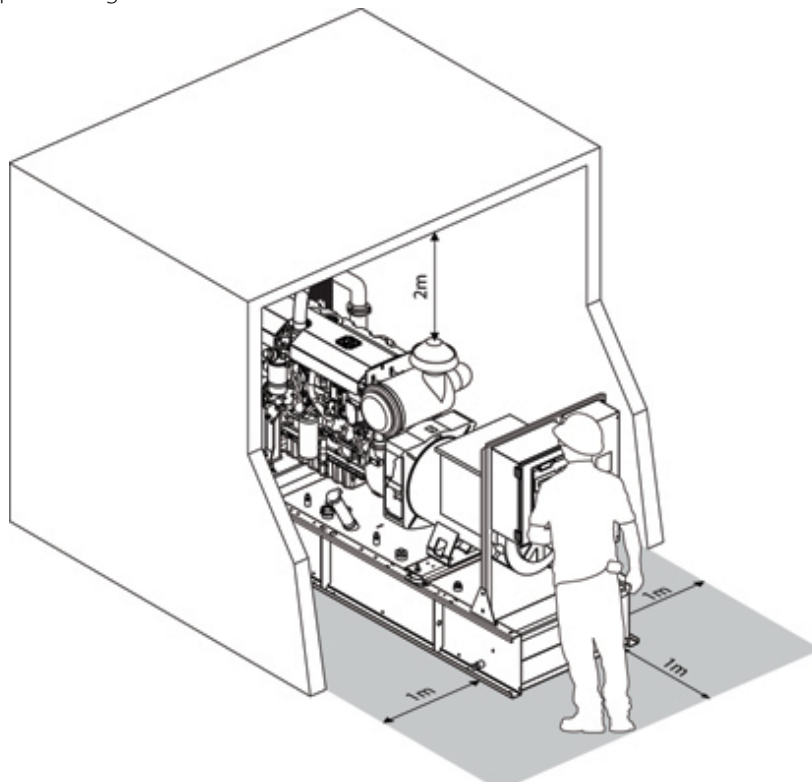

Figure 4.2 – Typical installation showing generator set access and operator workstation

4.2 Outdoor Installation

Installation and handling is greatly simplified when the generator set has been equipped with an enclosure. Two basic types may be fitted. The first type is a close fitting canopy enclosure. This will be both weatherproof and sound attenuated. The other enclosure type is a walk-in type container, similar to a shipping container. It may be weatherproof or sound attenuated.

These enclosures provide a self contained generator set system that is easily transportable and requires minimal installation. They also automatically give protection from the elements and protection from unauthorised access.

Warning:

- ⚠ **Make sure all personnel are out of the canopy or container, if equipped, before closing and latching enclosure doors.**
- ⚠ **Enclosures fitted with doors stays or lift off doors (when Applicable) should not be used when wind exceeds 15 mph.**
- ⚠ **Before closing canopy or enclosure doors, ensure all obstructions (especially hands and fingers) are clear to prevent damage or injury.**
- ⚠ **For transport purposes, some silencer outlets on generator sets housed in walk-in type enclosures will be fitted with cover plates. These are to be replaced with the supplied stub pipes complete with fitted rain hood.**
- ⚠ **Ensure there is no debris on the base frame prior to starting, as loose items will cause radiator damage.**

Because enclosed generator sets are easily transportable and may be installed and operated in a temporary location, many of the fixed installation details given in this chapter may not apply. The following considerations must be taken into account when temporarily installing the generator set:

- Locating the generator set where it will be protected from damage and away from the exhaust fumes of other engines or other airborne contaminants such as dust, lint, smoke, oil mist or vapours. Sound levels will vary depending on the configuration of the generator set and the final bolted down installation of the generator set on a flat surface
- Ensure the generator set is not positioned in such a way that it will obstruct the entrance or exit to the area where the it is situated.
- Locating the generator set on firm, level ground which will not subside or be otherwise affected by the vibration caused by the operation of the generator set
- Ensuring that fumes from the exhaust outlet will not be a hazard especially when wind is taken into account.
- Ensure there is enough area around the generator set for access and serviceability.
- Electrical grounding of the generator set at all times, in accordance with local regulations.
- Providing access to refill the fuel tank when required.
- Protecting electrical cables installed between the generator set and the load. If these are laid on the ground ensure they are boxed in or covered to prevent damage or injury to personnel.

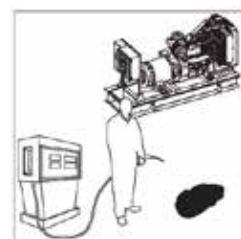
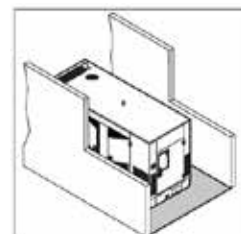
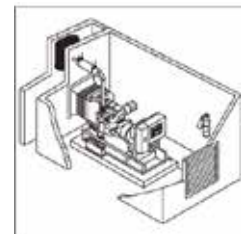
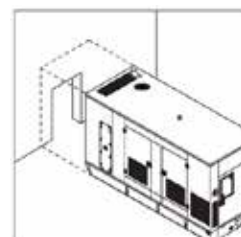

WARNING

- ⚠ **Enclosed generator sets should be installed outside. In the event that the enclosed generator set is installed inside, adequate fresh cooling air must be provided and that both engine and hot coolant air exhausts must be ducted outside the building. The ducting and exhaust pipework must be designed to minimise back pressure which would have a detrimental effect on generator set performance.**

4.2.1 Positioning of Walk-in Containers

Proper installation of the container is required if successful generation of power is to be achieved. The following information must be considered in the selection of the operating site for the container. The containerised generator set must be placed on a flat surface in order to maintain proper alignment. Containers can be successfully installed on a concrete plinth or level, natural surface. The foundation must bear the static weight of the module plus any dynamic forces from engine operation.

Warning:

- ⚠ **For generator sets housed in walk-in type containers, crankcase breather outlets terminated at the external face of the enclosure will be plugged. These must be removed prior to operation.**

4.2.2 Concrete Plinth

Setting the container on a concrete plinth is the preferred method for permanent installation for both ISO and Design to Order (DTO) containers. The concrete plinth should have been designed to withstand the weight of the container. Please consult the installer for further details.

4.2.3 Installation Location

The generator set must be parked on a flat surface such as a concrete pad or a level natural surface. Prepare the foundation for the operation of the generator set. The foundation must be able to bear the weight of the generator set and any forces from engine operation.

Railroad ties or wood beams beneath the base frame of the generator set, the landing gear, and the jack stands should be considered for the following conditions: loose soil, loose gravel, loose sand, and wet conditions. This procedure will prevent the generator set from settling into the soft surface due to the weight of the generator set. A concrete pad should be considered if the generator set will be operated at a site for a long time.

4.2.4 Exhaust Discharge

Heat from the engine will be expelled via the engine exhaust, other heat is removed from the cooling system as a cooling fan forces air through a radiator core. Both of these exhaust streams will leave the generator set and enter the surrounding atmosphere. When you choose a site, consider the hot exhaust that exits the generator set.

Position the generator set so there is no trees and plants in the path of the hot exhaust as any excessive heat may destroy them. The generator set should not be parked close to a building. The excessive heat may make building interiors uncomfortable. Do not place the air intake of a generator set in the location of the exhaust of another generator set.

Be aware of overhead power lines ensure that any power lines are not exposed to hot exhaust. Overhead power lines may also become coated with soot. An electric arc may develop between the exhaust soot and the ground if exhaust soot is allowed to build up on power lines.

4.3 Moving the Generator set

Prior to any movement or installation of the generator set please review the following steps

- ⚠ **Keep all non-essential personnel clear of the area.**
- ⚠ **Load the package and unload the package on a level surface.**
- ⚠ **Block the transport vehicle so the vehicle cannot move.**
- ⚠ **Keep both the trailer bed and the ramps for the trailer clean. Remove any clay, oil, or other slippery materials.**
- ⚠ **If ramps are used, ensure that the ramps are of adequate size and strength. The ramps should be installed at the proper height and the angle of the ramps should be low.**
- ⚠ **Use the lifting eye of the enclosure. Ensure that all the lifting devices have adequate capacity.**
- ⚠ **Chain the package or block the package securely before you transport the package.**
- ⚠ **Check the height and width of the package for clearance for traveling. Check the weight of the package for load limitations.**

The generator set base frame is specifically designed for ease of moving the set. Improper handling can seriously damage components.

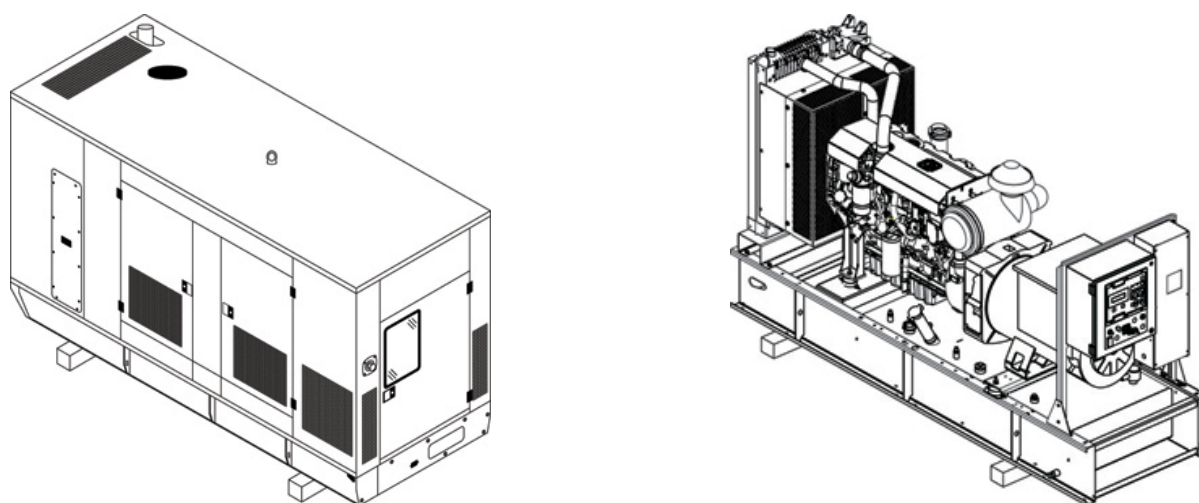

Figure 4.3 – Open and Closed generator sets on wooden skids

Using a forklift, the generator set can be lifted or carefully pushed/pulled by the base frame. If pushing, do not push the base frame directly with fork.

Warning:

- ⚠ **Always use wood between forks and the base frame to spread the load and also between the forklift carriage and the side of the canopy to prevent damage.**

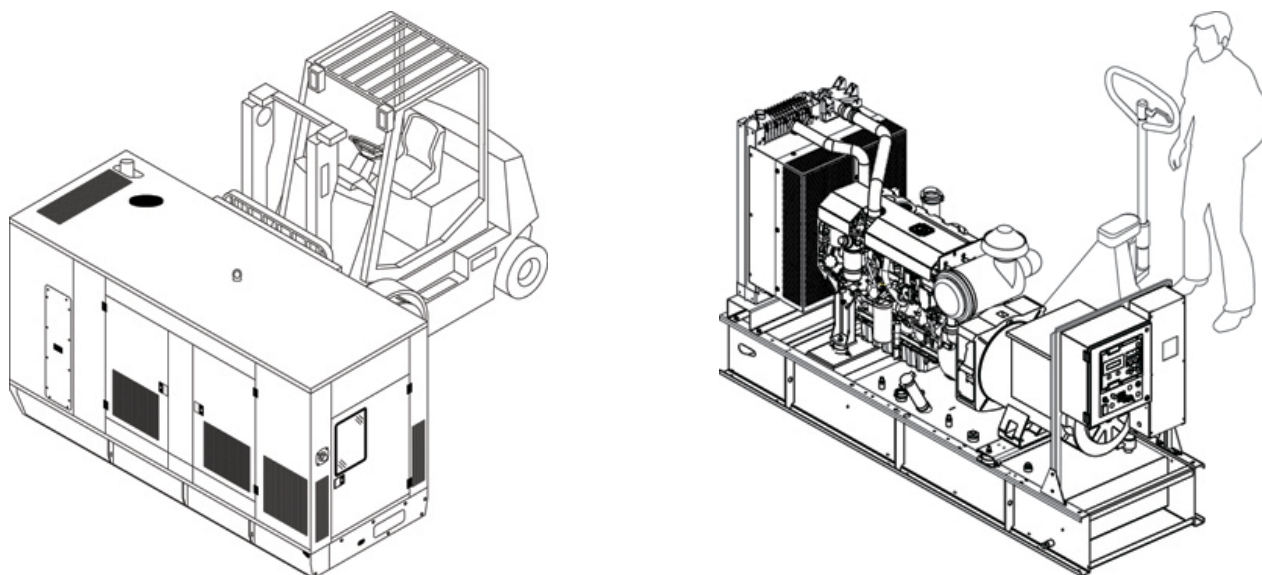

Figure 4.4 – Transporting a generator set using a forklift truck and forklift trolley

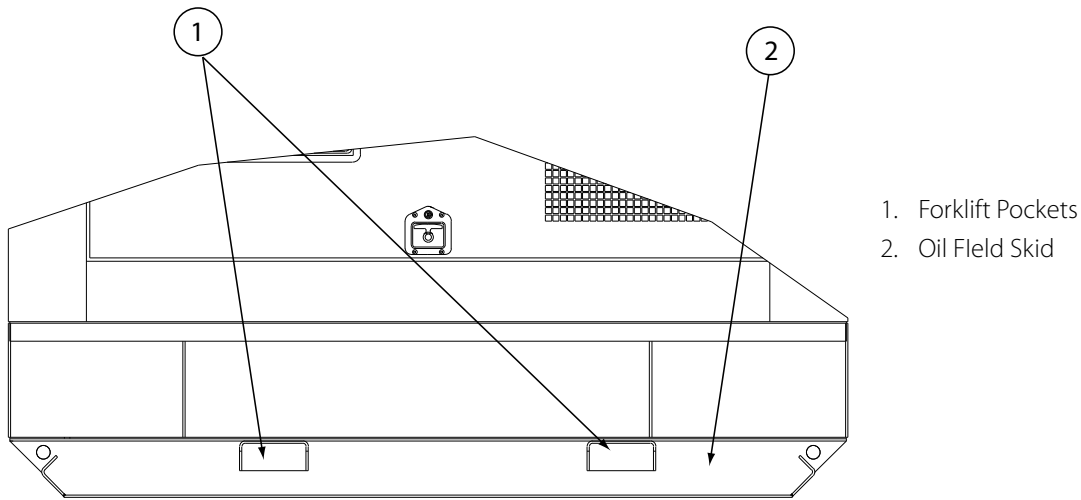

Figure 4.5 – Typical generator set with Oil Field Skid base option

If the generator set will be regularly moved, it should be fitted with the optional Oil Field Skid which provides forklift pockets in the base frame along with eyes for pulling. The smaller sets have forklift pockets in the base frame as standard.

Warning:

- ⚠ **Please ensure the fuel tank is empty when lifting the generator set to ensure safe and stable lifting.**
- ⚠ **Never lift the generator set by attaching to the engine or alternator lifting lugs.**
- ⚠ **Ensure the lifting rigging and supporting structure is in good condition and is suitably rated.**
- ⚠ **Keep all personnel away from the generator set when it is suspended.**

To lift and install the generator set you can use the single / two point lifting points or the lifting points provided on the baseframe. Points of attachment should be checked for cracked welds or loose nuts and bolts before lifting. A spreader bar is required to prevent damage to the generator set whilst lifting from the baseframe. It should be positioned over the centre of gravity, to allow a vertical lift. Generator sets fitted with dual point lift frame, the lifting eyes are positioned either side of the canopy to allow easy access. The lifting points are positioned as close to the center of gravity of the generator set as is possible. Guide ropes should be used to prevent twisting or swinging of the generator set once it has been lifted clear of the ground. Place the generator set down on a level surface capable of supporting its weight.

- ⚠ **Lifting eyes not intended for use shall be shielded with the appropriate lifting eye shield. Each shield shall display a "Do Not Lift" label. Refer to section 2.11**

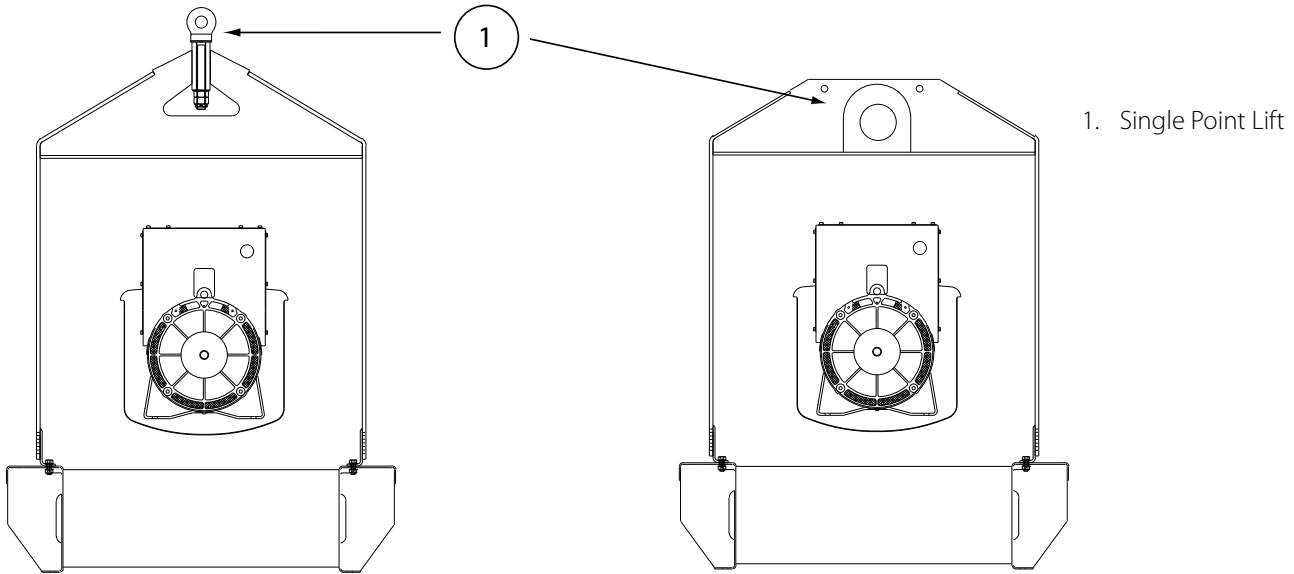

Figure 4.6 – Single Point lift

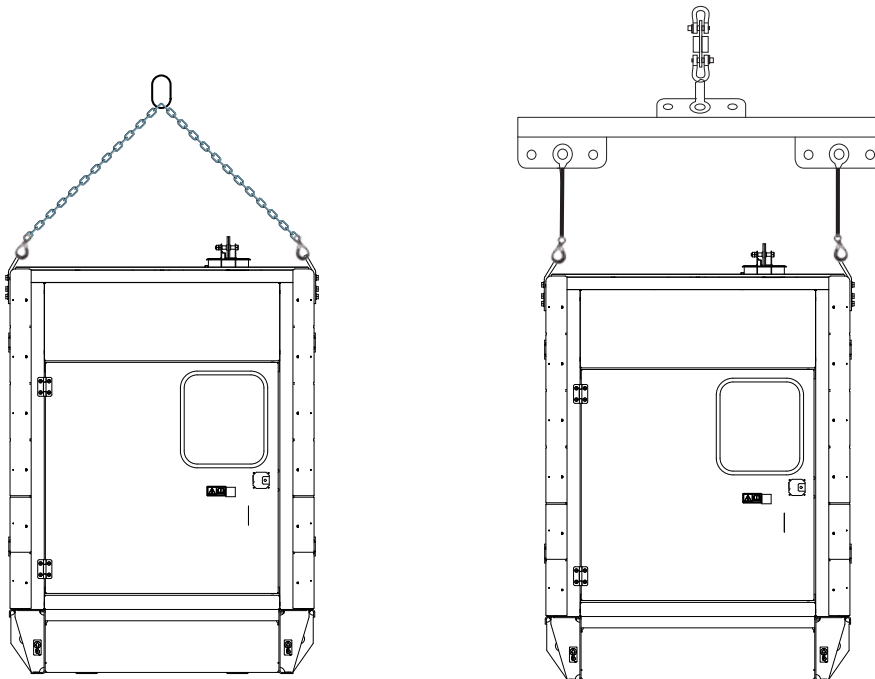

Figure 4.7 – Two Point lift

Warning

- ⚠ Please ensure the fuel tank is empty when lifting the generator set to ensure safe and stable lifting.
- ⚠ Centre of gravity decal is located on the base / canopy of the generator set.
- ⚠ The centre of gravity may not always be located at the centre of the generator set. The center of gravity will change depending on package options and also volume of liquid on board . The center of gravity shifting may cause lift angle to vary between $+5^\circ$ and -5° from horizontal. Ensure that generator set is not lifted if the angle of lift is outside these values.
- ⚠ Do not attempt to lift in high winds.

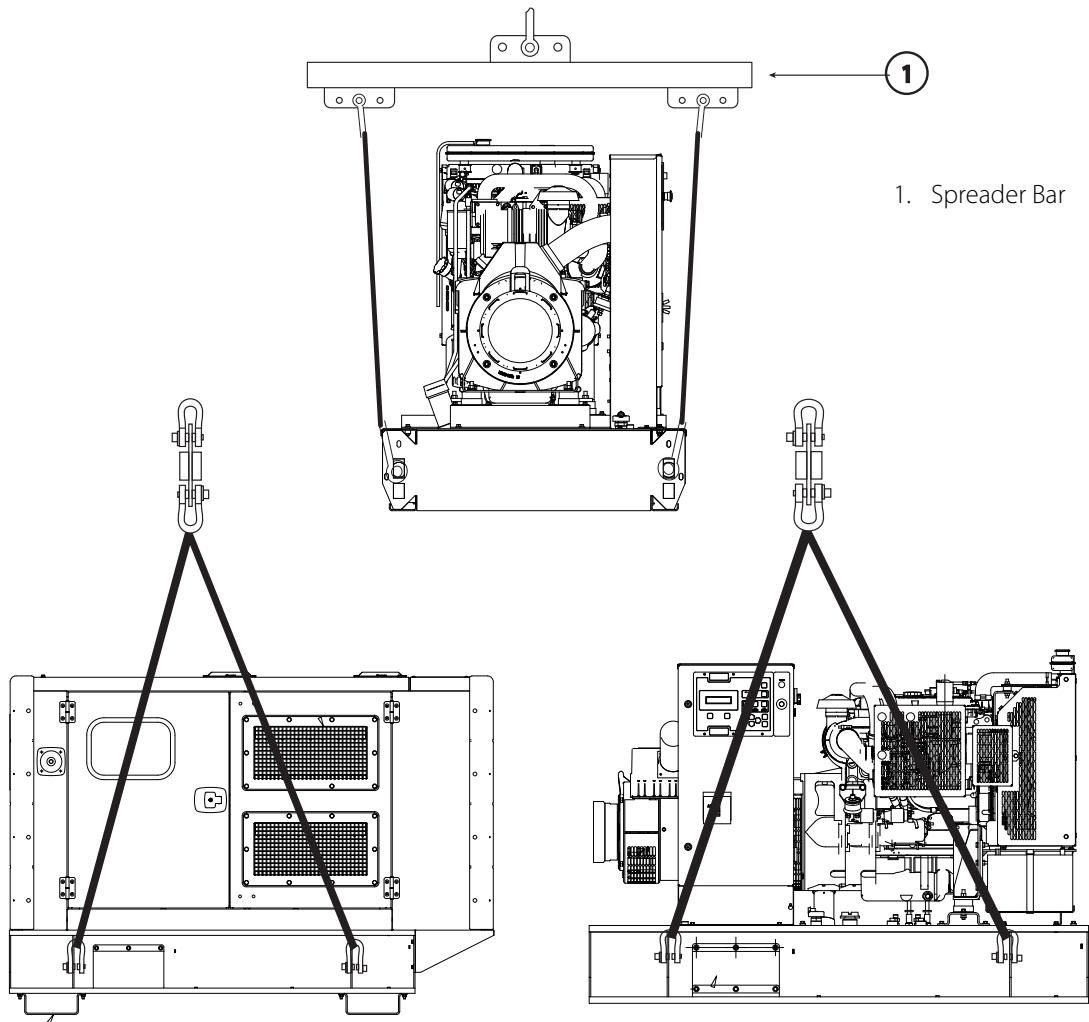

Figure 4.8 – Proper lifting arrangement for installing the generator set (open & enclosed)

4.3.1 Approved Lifting Methods for ISO Walk-in Containers

Containers are manufactured to ISO dimensions, ISO 1496-4:1994(E) and ISO 668:1995(E). To ensure the safety of all personnel involved with the handling of containers, it is important that the correct lifting and handling procedures are employed. The procedures detailed below are derived from ISO 3874:1997(E) and must be followed at all times.

ISO Series 1 Freight Containers			
Lift Description	Loaded / Unloaded	Method	Diagram
Top Lift	Unloaded Only	A single pint lift with rated shackles	
Top Lift	Loaded	A vertical lift by means of a spreader bar and rated CAMLOK-CLB type lugs	
Bottom Lift	Loaded	Lifting from bottom four corner casting using CAMLOK-CLB type lugs and rated spreader beam	
Bottom Lift	Loaded and Unloaded	Lifting from bottom four corner castings using CAMLOK-CLB type lugs and nylon straps	

Figure 4.9 – Lifting method for ISO Series 1 Freight Containers

4.3.2 Approved Lifting Methods for Non-ISO Walk-in Containers

Containers can be manufactured to non-ISO dimensions. To ensure the safety of all personnel involved with the handling of containers, it is important that the correct lifting and handling procedures are employed. The procedures for handling non-ISO containers are detailed below and must be followed at all times.

ISO Series 1 Freight Containers			
Lift Description	Loaded / Unloaded	Method	Diagram
Bottom Lift	Loaded and Unloaded	Lifting from bottom four lifting lugs using rated shackles	

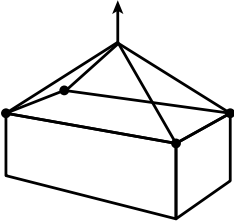
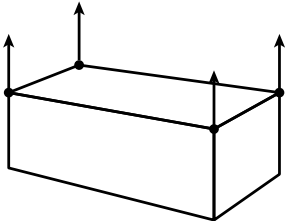
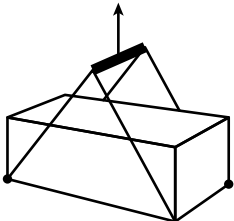
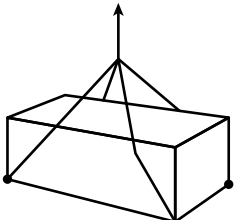
Figure 4.10 – Lifting method for Non-ISO Containers

4.4 Foundations and Vibration Isolation

The generator set is supplied on a rigid base frame that precisely aligns the alternator and engine and needs only be bolted down to a suitably prepared surface.

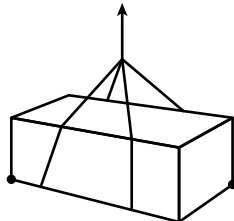
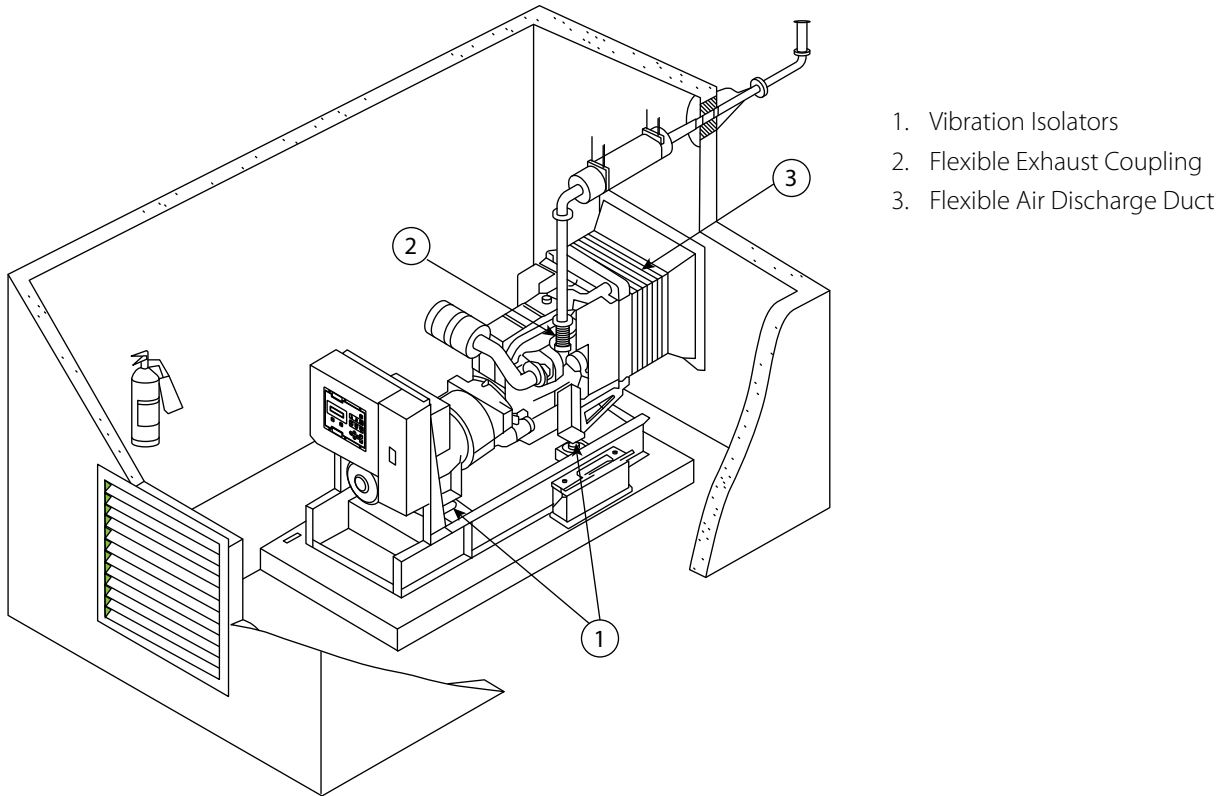

Figure 4.11 – Typical installation highlighting vibration reduction techniques

4.4.1 Foundation

A reinforced concrete pad makes the best foundation for the generator set. It provides a rigid support to prevent deflection and vibration. Typically the foundation should be from 150 mm to 200 mm (6 to 8 inches) deep and at least 150 mm (6 inches) wider and longer than the generator set. The ground or floor below the foundation should be properly prepared and should be structurally suited to carry the combined weight of the foundation pad and the generator set. (If the generator set is to be installed above the ground floor the building structure must be able to support the weight of the generator set, fuel storage and accessories.) Relevant building codes should be consulted and complied with. If the floor is wet from time to time, such as in a boiler room, the pad should be raised above the floor. This will provide a dry footing for the generator set and for those who connect, service or operate it. It will also minimise corrosive action on the base frame.

4.4.2 Vibration Isolation

To minimise engine vibrations being transmitted to the building, the generator set is fitted with vibration isolators. On small and medium sized generator sets these isolators are fitted between the engine/alternator feet and the base frame. This allows the frame to be rigidly bolted to the foundation. On larger generator sets the coupled engine/alternator is rigidly attached to the base frame and the vibration isolators are supplied loose for fitting between the base frame and the foundation. In all cases the sets should be securely bolted to the ground (either through the base frame or through the vibration isolators) to prevent movement.

Vibration isolation is also required between the generator set and its external connections. This is achieved by the use of flexible connections in the fuel lines, exhaust system, radiator air discharge duct, electrical conduit for control and power cables and other externally connected support systems.

4.5 Storage

Long term storage can have detrimental effects on both the engine and alternator. These effects can be minimised by properly preparing and storing the generator set.

4.5.1 Engine Storage

The engine should be put through an engine "preservation" procedure that includes cleaning the engine and replacing all the fluids with new or preserving fluids. Please consult your local Dealer for more information on engine storage.

4.5.2 Alternator Storage

When an alternator is in storage, moisture tends to condense in the windings. To minimise condensation, store the generator set in a dry storage area. If possible use space heaters to keep the windings dry.

Please consult your local Dealer for more information on alternator storage.

4.5.3 Battery Storage

While the battery is stored, it should receive a refreshing charge every 12 weeks (8 weeks in a tropical climate) up to a fully charged condition.

5. CONTROL SYSTEM DESCRIPTION AND TROUBLE SHOOTING

5.1 Control System Description

An electronic control system has been designed and installed to control and monitor the generator set. Depending on the requirements of the generator set, one of several different standard control systems may be fitted. Other more specialised systems may be fitted for specific installations in which case separate documentation is provided.

These control systems consist of three major components working together:

Control Panel – provides a means of starting and stopping the generator set, monitoring its operation and output and automatically shutting down the generator set in the event of a critical condition arising such as low oil pressure or high engine coolant temperature to prevent major damage to the engine / alternator.

Engine Interface Module (where fitted) - provides switching relays for the Starter Motor Solenoid, Glow Plug and Fuel Solenoid. Each of these circuits is protected with individual fuses mounted in the module. Individual LED's illuminate when each circuit is energised.

Power Output Circuit Breaker - serves to protect the alternator by automatically disconnecting the load in the event of overload or short circuit. It also provides a means of switching the generator set output.

5.1.1 Pre-Start Checks (applicable to all control systems)

Warning

⚠ The following checks detailed below are the only tasks that an operator should undertake.

The following checks should be performed prior to starting the generator set:

1. A visual inspection should take only a few minutes and can prevent costly repairs and accidents – For maximum generator set life, visually inspect the generator set before starting. Look for items such as:
 - Loose fastenings / fixings, worn belts or loose connections. Repair as necessary.
 - The fan and exhaust guards must be at the correct positions and securely fixed. Repair damaged / loose guards or renew missing guards.
 - Wipe clean all filler caps before the engine is serviced or fluids are topped up to reduce the chance of any system contamination.
 - For any type of leak (coolant, lubricating oil or fuel), clean away the fluid. If a leak is observed, find the source and correct the leak. If a leak is suspected, check the fluid levels frequently until the leak is found and repaired.
 - Accumulated grease and / or oil on an engine is a fire hazard. Remove it by steam cleaning or by the use of a high pressure water jet. Avoid high-pressure water on the electronic/electrical components provide suitable protection were possible.
 - Ensure that the coolant pipes are fitted correctly and that they are secure. Check for leaks. Check the condition of all pipes for splits or signs of rubbing.

Fluid levels

2. Check the engine oil and coolant levels – replenish as necessary (see engine handbook for locations). Ensure fluids used are as recommended within the engine handbook.

Warning:

⚠ Do not remove the radiator cap or any component of the cooling system while the engine is running and while the coolant is under pressure, because dangerous hot coolant can be discharged, posing a risk of personal injury. Do not add large amounts of cold coolant to a hot system as serious engine damage could result.

Note:

- Diesel engines normally consume lube oil at a rate of 0.25% to 1% of the fuel consumption.
- When adding coolant to the radiator system, always pour slowly to help prevent air from becoming trapped in the engine. Always top up when engine is cold.

Warning:

⚠ When filling the fuel tank, do not smoke or use an open flame in the vicinity.

3. Check the fuel level – fill as necessary. Drain water from the water separator (if equipped)

Warning:

- ⚠ **Before tightening the fan belts, disconnect the battery negative (-) lead to ensure the engine cannot be accidentally started.**
- 4. Check the condition and tension of the fan and engine alternator belts – tighten as necessary.
- 5. Check all hoses for loose connections or deterioration – tighten or replace as necessary.
- 6. Check the battery terminals for corrosion – clean as necessary.

Warning:

- ⚠ **When working with the batteries, do not smoke or use an open flame in the vicinity. Hydrogen gas from batteries is explosive.**
- ⚠ **Do not short the positive and negative terminals together.**
- 7. Check the battery electrolyte level – fill with distilled water as necessary.
- 8. Check the control panel and the generator set for heavy accumulation of dust and dirt – clean as necessary. These can pose an electrical hazard or give rise to cooling problems.
- 9. Check the air filter restriction indicator, if fitted – replace the filter as necessary.
- 10. Clear the area around the generator set of any insecure items that could inhibit operation or cause injury. Ensure cooling air ventilation screens are clear.
- 11. Visually check the entire generator set for signs of leaks from the fuel system, cooling system or lubrication seals.
- 12. Periodically drain exhaust system condensate traps, if equipped.
- 13. If fluid containment is incorporated into the baseframe it must be inspected. Any liquids present (fuel, oil, coolant, rainwater or condensation) should be drained out and disposed of in accordance with local regulations and mandates.
- 14. Ensure the Alternator Output Circuit Breaker is in the “OFF” (handle down) position.

5.2 PowerWizard 1.1, 1.1+ & 2.1 (Quickstart)

5.2.1 General Information

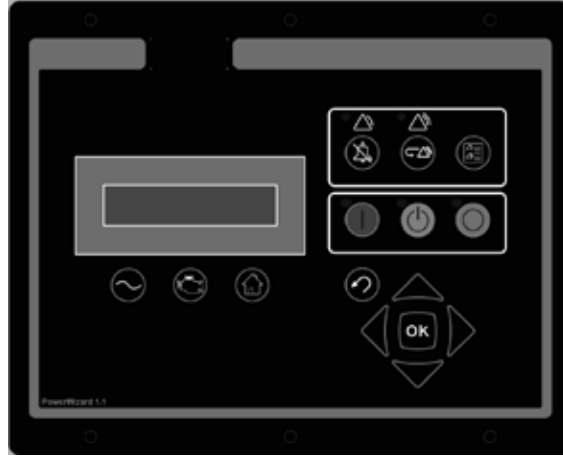

Figure 5.1 – PowerWizard Control System Panel

The controller is available in three versions, PowerWizard 1.1, 1.1+ and 2.1. These three versions are based on different features. This guide is intended to cover the PowerWizard generator set Control and its application in generator set systems.

5.2.2 PowerWizard Control Module Description

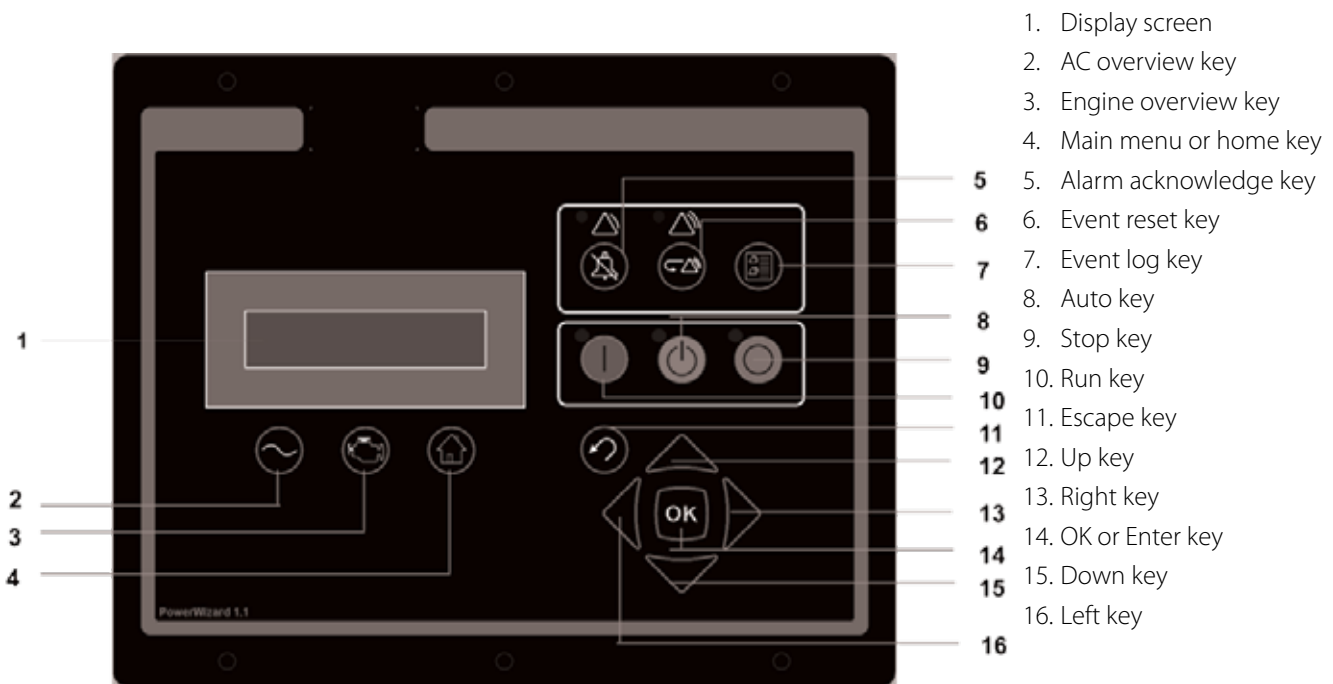

Figure 5.2 – PowerWizard Control Module Description

5.2.3 Basic Operation

START Mode

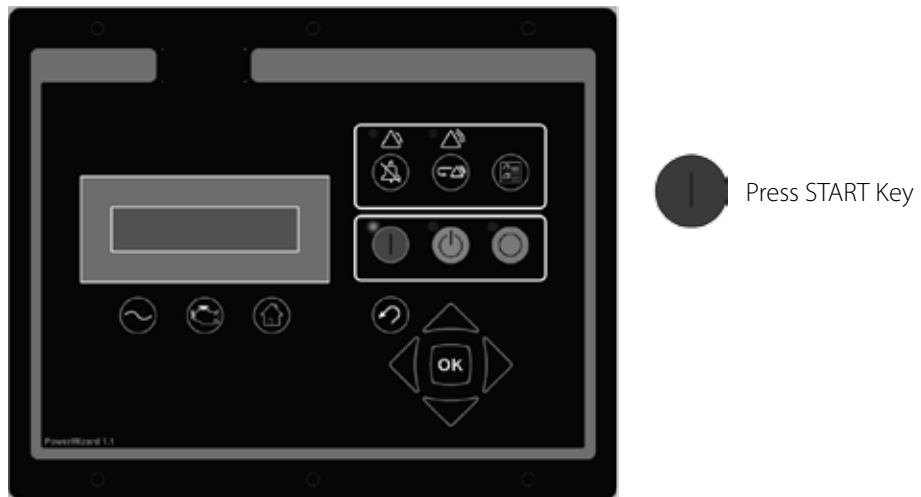

Figure 5.3 – Basic Operation Start Key

STOP Mode

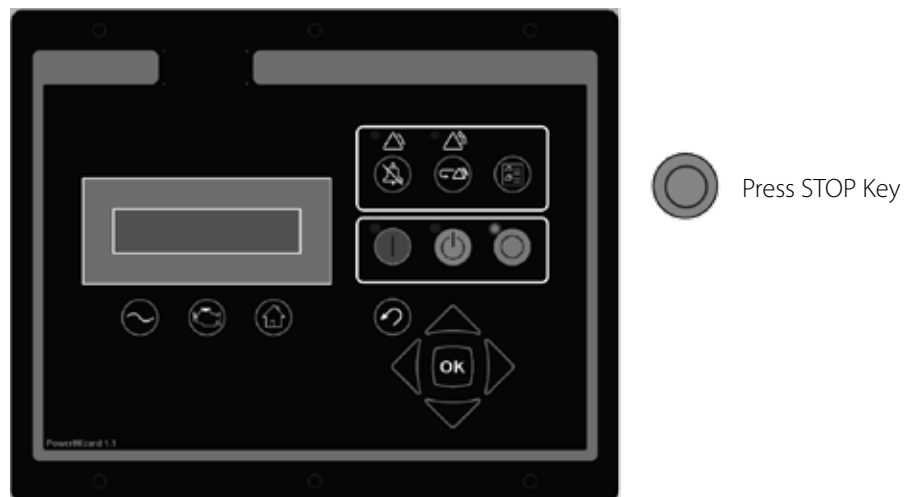

Figure 5.4 – Basic Operation Stop Key

AUTO Mode

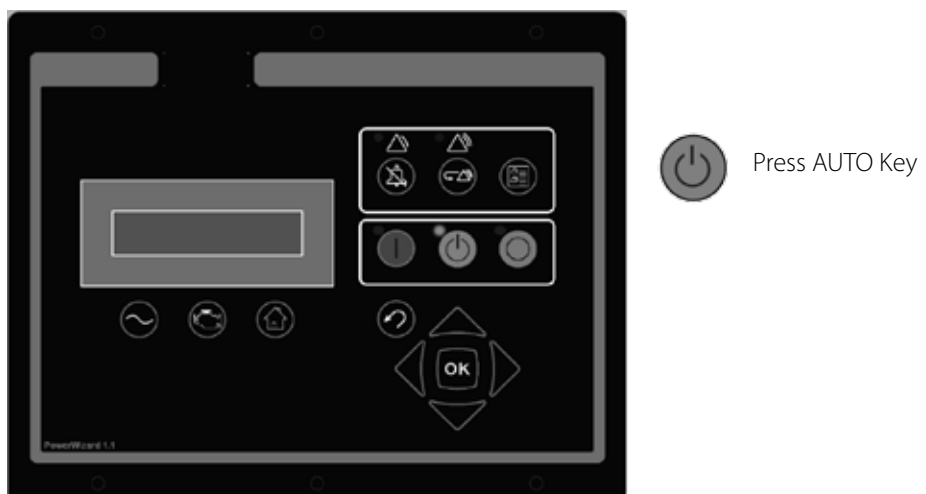

Figure 5.5 – Basic Operation Auto Key

Note:

- When not using PowerWizard in AUTO mode a "Not in Auto Mode" activate alarm will sound (where enabled).

5.2.4 Fault / Alarm Reset Process

1. Fault / Alarm Reset Process

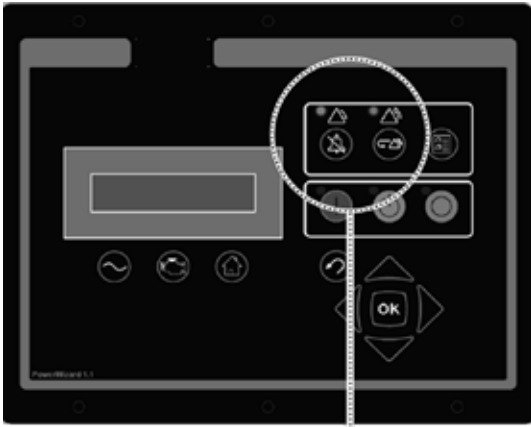

If either of these indication lamps are flashing or solid there is a warning or shutdown

3. Fault / Alarm Reset

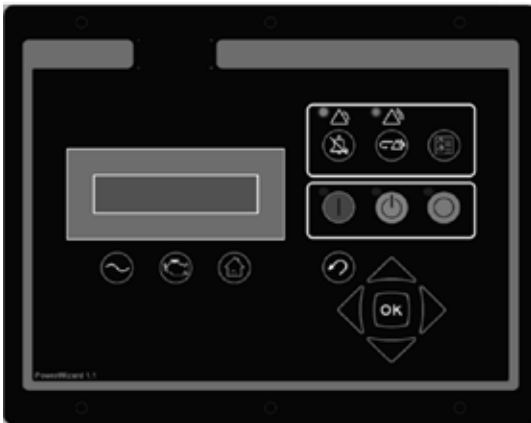

Press and hold "Alarm Acknowledge" key for 3 seconds

2. Fault / Alarm Reset

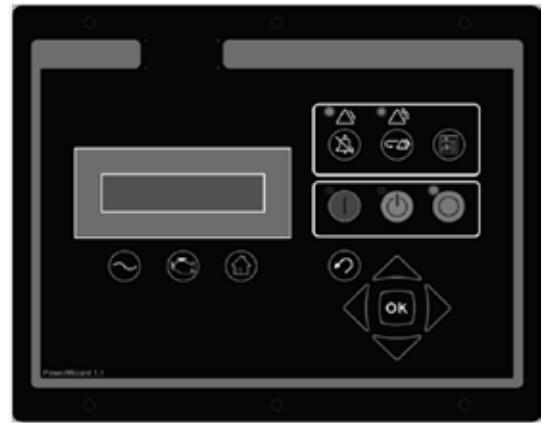

Press **STOP** Key

4. Fault / Alarm Reset Process. The display will show:

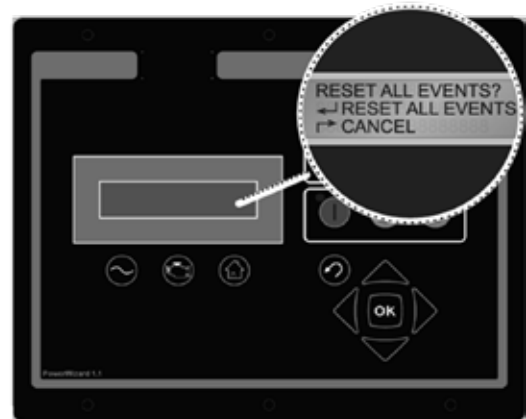

Press **ENTER** Key to clear all Warnings and / or Shutdowns



Press **ESCAPE** Key to cancel

Figure 5.6 – Basic Operation Fault Alarm Reset Process

5.2.5 User Interface Overview

Before starting or running the generator set, the operator should become fully acquainted with the control module's display and push buttons. The display should be observed from time to time while the generator set is running so that any abnormal readings can be detected before problems arise. Addition of optional equipment may add items to the panel so that the panel fitted on the generator set may be slightly different from the typical one shown. The following descriptions explain the function of each standard item on the panels:

Function Keys:

- 

AC Overview key – The AC Overview key will navigate the display to the first screen of AC information. The AC Overview information contains various AC parameters that summarise the electrical operation of the generator set. (Use the up/down keys to navigate within the AC parameters).
- 

Engine Overview key – The Engine Overview key will navigate the display to the first screen of engine information. The Engine Overview information contains various engine parameters that summarise the operation of the generator set. (Use the up / down keys to navigate within the Engine parameters).
- 

Main Menu key – The Main Menu key will navigate the display to the main menu screen. Pressing the navigation keys will allow access to menus at all levels.

Control Keys:



RUN – Pressing the Run key will cause the engine to enter the run mode.



AUTO – Pressing the Auto key will cause the engine to enter the auto mode.



STOP – Pressing the Stop key will cause the engine to enter stop mode.

Navigation Keys:



Scroll Up – The Scroll Up key is used to navigate up through the various menus or monitoring screens. The Scroll Up key is also used during setpoint entry. During numeric data entry the Scroll Up key is used to increment the digits (0–9). If the setpoint requires selection from a list, the Scroll Up key is used to navigate through the list.



Escape – The Escape key is used during menu navigation in order to navigate up through the menu/sub-menu structure. Each key press causes the user to move backwards/upwards through the navigation menus. The Escape key is also used to exit/cancel out of data entry screens during setpoint programming. If the Escape key is pressed during setpoint programming, none of the changes made on screen will be saved to memory.



Scroll Right – The Scroll Right key is used during setpoint adjustment. During numeric data entry, the Scroll Right key is used to choose which digit is being edited. The Scroll Right key is also used during certain setpoint adjustments to select or deselect a check box. If a box has a check mark inside, pressing the Scroll Right key will cause the check mark to disappear, disabling the function. If the box does not have a check mark inside, pressing the Scroll Right key will cause a check mark to appear, enabling the function.



Enter / OK – The Enter key is used during menu navigation to select menu items in order to navigate forward/downward in the menu/sub-menu structure. The Enter key is also used during setpoint programming in order to save setpoint changes. Pressing the Enter key during setpoint programming causes setpoint changes to be saved to memory.



Scroll Down – The Scroll Down key is used to navigate down through the various menus or monitoring screens. The Scroll Down key is also used during setpoint entry. During numeric data entry the Scroll Down key is used in order to decrement the digits (0–9). If the setpoint requires selection from a list, the Scroll Down key is used to navigate down through the list.



Scroll Left – The Scroll Left key is used during setpoint adjustment. During numeric data entry, the Scroll Left key is used to choose which digit is being edited. The Scroll Left key is also used during certain setpoint adjustments to select or deselect a check box. If a box has a check mark inside, pressing the Scroll Left key will cause the check mark to disappear, disabling the function. If the box does not have a check mark inside, pressing the Scroll Left key will cause a check mark to appear, enabling the function.

Event Keys and Indicators:



Yellow Warning Light – A flashing yellow light indicates that there are unacknowledged active warnings. A solid yellow light indicates that there are acknowledged warnings active. If there are any active warnings, the yellow light will change from flashing yellow to solid yellow after the Alarm Acknowledge key is pressed. If there are no longer any active warnings, the yellow light will turn off after the Alarm Acknowledge key is pressed.



Red Shutdown Light – A flashing red light indicates that there are unacknowledged active shutdown events. A solid red light indicates that there are acknowledged shutdown events active. If there are any active shutdown events the red light will change from flashing red to solid red after the Alarm Acknowledge key is pressed. Any condition that has caused a shutdown event must be manually reset. If there are no longer any active shutdown events, the red light will turn off.



Alarm Acknowledge – Pressing the Alarm Acknowledge will cause the horn relay output to turn off and silence the horn. Pressing the key will also cause any yellow or red flashing lights to turn off or to become solid depending on the active status of the alarms.



Event Reset Key – Pressing the Event Reset key will reset all events when the control is in the stopped position. However, “Reset All Events” will not reset “Present” events.



Event Log Key – Pressing the Event Log key will navigate to the “Active Events” menu. In order to scroll through the events, use the up and down keys. After highlighting an event, press the “OK” key to see information about the event such as the SPN and the FMI.



EMERGENCY STOP Push button – A red lock-down push button that immediately shuts down the generator set and will inhibit start until the push button has been released by turning it clockwise. Prior to restarting the set, this fault must be reset by pressing the “stop” button on the module and resetting the fault in the “event log menu”.

Display Preferences for PowerWizard Panels:

To change the display preferences, from the main menu scroll down to the “Preferences” item (last in the menu). Press the “Enter” Key. Scroll down through the preferences menu until the desired display preference is highlighted. Press “Enter” to adjust this preference.

CONTRAST: The display contrast may require adjustment from the factory default depending on viewing angle and ambient temperature. The contrast is adjusted between 0% and 100% by pressing the “Left” and “Right” keys. Pressing “Enter” accepts the changes and “Escape” aborts the changes.

BACKLIGHT: The backlight is usually left at 100%, however on occasions the user may wish to reduce the backlight intensity. The backlight can be adjusted between 0 to 100% by pressing the “Left” and “Right” keys. Pressing “Enter” accepts the changes and “Escape” aborts the changes.

PRESSURE UNITS: The pressure units can be adjusted between kPa/psi/bar. Use the “Left” and “Right” keys to select the preferred pressure units. Pressing “Enter” accepts the new pressure units; pressing “Escape” aborts the change in pressure units.

TEMPERATURE UNITS: The temperature units can be adjusted between °C and °F. Use the “Left” and “Right” keys to select the preferred temperature units. Pressing “Enter” accepts the change; pressing escape aborts the change.

VOLUME: Volume is used on some optional parameters (such as fuel consumption rate). It can be selected between Litres, US Gallons and Imperial Gallons using the “Left” and “Right” keys. Pressing “Enter” accepts the new volume units; pressing “Escape” aborts the change to the volume units.

LAMP TEST: This is used to test the LEDs and display. When LAMP TEST is highlighted, pressing OK will turn on all LEDs and display screen.

5.2.6 Alarm Log and Resetting

Note:

- To reset the menu back to the start, please press the “Escape” key three times.

Event Viewing

There are two ways to view events. Pressing the “EVENT LOG” key navigates directly to the “ACTIVE EVENTS” menu. The other way is to use the Main Menu:

1. From the MAIN MENU/VIEW, highlight “EVENT LOGS” and press the “Enter” key. The “ACTIVE EVENTS” menu will be displayed in this menu.
2. In order to scroll through the events use the up and down keys. Events are ordered with present events first, active events next and inactive events last. Within these classifications they are ordered by engine run hours (or real time clock on PowerWizard 2.1).
3. Press “Enter” after highlighting an event to see additional information such as SPN, FMI, time and date of first occurrence, time and date of last occurrence (PowerWizard 2.1 only), engine hours at first occurrence and engine hours at last occurrence.

Quick Shut Down Resetting

In addition to the above procedure there is also a simplified process for resetting all events. To reset all events:

1. Ensure that the control is in the stopped position.
2. Press the “Reset Event” key from any screen.
3. A confirmation prompt will appear.
4. Press the “OK” key to reset all events on all modules. Press the ‘ESCAPE’ key to cancel the reset operation.

Note:

- The PowerWizard must be in stop mode to reset events.

Present events cannot be reset.

Shut Down Resetting

A flashing red shutdown light indicates there is an unacknowledged shutdown event. The red shutdown light will change from flashing red to solid red when the Alarm Acknowledged key is pressed. Once a fault has been checked and the cause rectified, use the following procedure in order to reset the event:

1. Press the "Stop" key.
2. Enter the "EVENT LOGS" option from the main menu.
3. Select a "Module" from the list.
4. Scroll through the events in order to highlight the event to be reset.
5. Make sure the event status is active (not present).
6. Press the "Enter" key.
7. "RESET" will be highlighted if the condition is no longer present and the control is in stop.
8. Press the "Enter" key again. The fault will clear.
9. Press the "Escape" or "Main Menu" key in order to get back to the main menu.

5.2.7 Security

There are 3 levels of password protection on the PowerWizard control panel. All of the adjustable setpoints are associated with a specific level of security required to make an adjustment to the parameter. The passwords only affect changing setpoints within the control panel.

The level of password protection that is required for each setpoint is identified on the parameter setpoint entry screen. A security level identification number "1", "2" or "3" next to a padlock symbol is displayed on the parameter setpoint entry screen. A Level 3 security is used for the most secure setpoints and Level 1 security is used for the least secure setpoints. If the PowerWizard is currently at the required level of protection when viewing a parameter, the padlock will not appear.

If a parameter is displayed with a padlock but no security level identification number next to it, the parameter cannot be changed from the PowerWizard display and the Dealer must be contacted. Level 1 and 2 passwords are disabled when installed. Level 1 and 2 passwords are user level passwords and can be used if desired.

The PowerWizard 2.1 also has a SCADA password, which can be used to secure remote communications.

To view the security menu:

MAIN MENU > CONFIGURE > SECURITY.

At the top of the security menu the current security level is displayed. Within the security menu are the following options:

DROP TO MINIMUM LEVEL – used to return the current security level to the lowest level set-up. Highlight and press Enter to drop to minimum security level. If no Level 1 or 2 passwords are set-up the minimum level will be 2. If a Level 2 password is set-up, the minimum level will be 1 and if a Level 1 password is set-up the minimum level will be 0.

ENTER LEVEL 1 OR 2 – used to enter Level 1 or 2 passwords. Highlight and press Enter to proceed to the password entry screen. Passwords can be entered using the cursor keys. In PowerWizard, Level 1 and 2 passwords must be different. An entered password is compared against the stored Level 1 and 2 passwords, if the password is correct the PowerWizard will go to the corresponding security level.

ENTER LEVEL 3 – used to obtain Level 3 access. The Level 3 security password is reserved for critical setpoints that should only be changed by a skilled operative. As such you must contact your Dealer if you require a change associated with a Level 3 password.

CHANGING LEVEL 1 PASSWORD – used to set-up, change or disable a Level 1 password. In order to use this feature the control must be at current security Level 1 or higher. Highlight and press Enter to proceed to the password entry screen. To set-up or change the password, enter the new password using the cursor keys. Passwords may be 16 digits long. To disable the Level 1 security password, set the password to '0'. Press the Enter key to save.

CHANGING LEVEL 2 PASSWORD – used to set-up, change or disable a Level 2 password. In order to use this feature the control must be at current security Level 2 or higher. Highlight and press Enter to proceed to the password entry screen. To set-up or change the password, enter the new password using the cursor keys. Passwords may be 16 digits long. To disable the Level 2 security password, set the password to '0'. Press the Enter key to save.

CHANGING SCADA PASSWORD (PowerWizard 2.1 only) – used to set-up, change or disable a SCADA password. Highlight and press enter to proceed to the password entry screen. To set-up or change the password, enter the new password using the cursor keys. Passwords may be 16 digits long. To disable the SCADA security password, set the password to '0'. Press the Enter key to save.

5.2.8 Real Time Clock Programming (PowerWizard 2.1)

The real time clock provides information for the time and date of an automatic time based start/stop control. It also provides a mechanism for time stamps in the event log. The real time clock is not calibrated and is for information only. The date and time are set by the user.

1. In order to set the time or date format:
MAIN MENU > CONFIGURE > TIME/DATE.
2. To set the time, highlight the time then press the "Enter" key twice.
3. Use the cursor keys to set the time and press the "Enter" key to save. Press the "Escape" key to return.
4. To set the date, highlight the date then press the "Enter" key twice.
5. Use the cursor keys to set the date and press the "Enter" key to save. Press the "Escape" key to return.
6. To set the date format, highlight either the FORMAT DD/MM/YY or FORMAT MM/DD/YY and press the "Enter" key.
7. Use the cursor keys to select the required date format and press the "Enter" key to save.

5.2.9 Fuel Transfer (PowerWizard 2.1)

Fuel pump in connection with fuel level measurement can be controlled to transfer diesel to the fuel tank.

1. In order to set the Fuel Transfer operation:
MAIN MENU > CONTROL > FUEL TRANSFER
2. To start or stop the fuel pump, highlight the PUMP CONTROL then press the "OK" key.
3. Use the cursor key to select START FUEL PUMP or STOP FUEL PUMP and press the "OK" key.
4. Auto Fuel Load Pump On and Off thresholds are set at 25% and 75% respectively.

5.2.10 Additional Features Available

Reduced Power Mode

In reduced power mode the screen will go blank and LED's will flash intermitently. Pressing any key will bring the panel out of reduced power mode. Reduced power mode can be disabled (Refer to your local Dealer).

Remote Annunciation of Faults

The PowerWizard Annunciator is used in remote applications, mounted separately from the generator set to provide remote indication of system operating and alarm conditions.

For further information on these features, please contact your Dealer.

5.2.11 Trouble Shooting Guide for PowerWizard

Fault	Symptom	Remedy
Engine Fails To Start	Engine Does Not Crank When Start Signal Is Given, Either Manually Via Run Key Or Automatically Via A Remote Signal	<ol style="list-style-type: none"> 1. Check All Emergency Stop Push Buttons Are Released 2. Check The Stop Button Light Is Not On 3. Check There Are No Shutdown Events Active. Reset, If Required, After Remedying The Indicated Fault 4. Refer To Your Local Dealer
Engine Stops Due To Low Oil Pressure	"LOW OIL PRESSURE" In Event Log. Red Shutdown Led Illuminates	<ol style="list-style-type: none"> 1. Check Oil Level 2. Refer To Your Local Dealer
Engine Stops Due To High Coolant Temp	"HIGH COOLANT TEMP" In Event Log. Red Shutdown Led Illuminates	<ol style="list-style-type: none"> 1. Check Coolant Level In The Radiator. Refer To Safety Section Before Removing The Radiator Cap 2. Refer To Your Local Dealer
Engine Stops Due To Overspeed	"OVERSPEED" In Event Log. Red Shutdown Led Illuminates	<ol style="list-style-type: none"> 1. Verify The Actual Engine Speed 2. Refer To Your Local Dealer
Engine Stops Due To Under-Voltage (Powerwizard 2.1 Only)	"UNDER-VOLTAGE" In Event Log, Red Shutdown Led Illuminates	<ol style="list-style-type: none"> 1. Refer To Your Local Dealer
Engine Stops Due To Over-Voltage (Standard On Powerwizard 2.1, Optional On Powerwizard 1.1+)	"Over-Voltage" In Event Log, Red Shutdown Led Illuminates	<ol style="list-style-type: none"> 1. Refer To Your Local Dealer
Generator set Does Not Go On Load	Generator set Is Running But The Load Is Not Being Powered	<ol style="list-style-type: none"> 1. Refer To Your Local Dealer
Generator set Does Not Stop Manually	Generator set Keeps Running After Being Switched Off	<ol style="list-style-type: none"> 1. Check That The Generator set Stops When The Emergency Stop Push button Is Depressed 2. Refer To Your Local Dealer
Generator set Does Not Stop When In Auto Mode	Generator set Does Not Stop After Remote Start Signal Is Removed	<ol style="list-style-type: none"> 1. Check That The Generator set Stops When The Emergency Stop Push button Is Depressed Or The Stop Key Is Held Down For 5 Seconds And The Cooldown Time Is Skipped
Alarm For Not In Auto Mode (Standby Sets Only)	"Not In Auto Mode" Alarm In Event Log, Amber Led Illuminates	<ol style="list-style-type: none"> 1. Check The Module Is In "Auto" Mode 2. Check Emergency Stop Push buttons Are Not Pressed 3. Refer To Your Local Dealer

5.3 PowerWizard 2.1+ / 4.1

5.3.1 PowerWizard 2.1+ Control Module Description

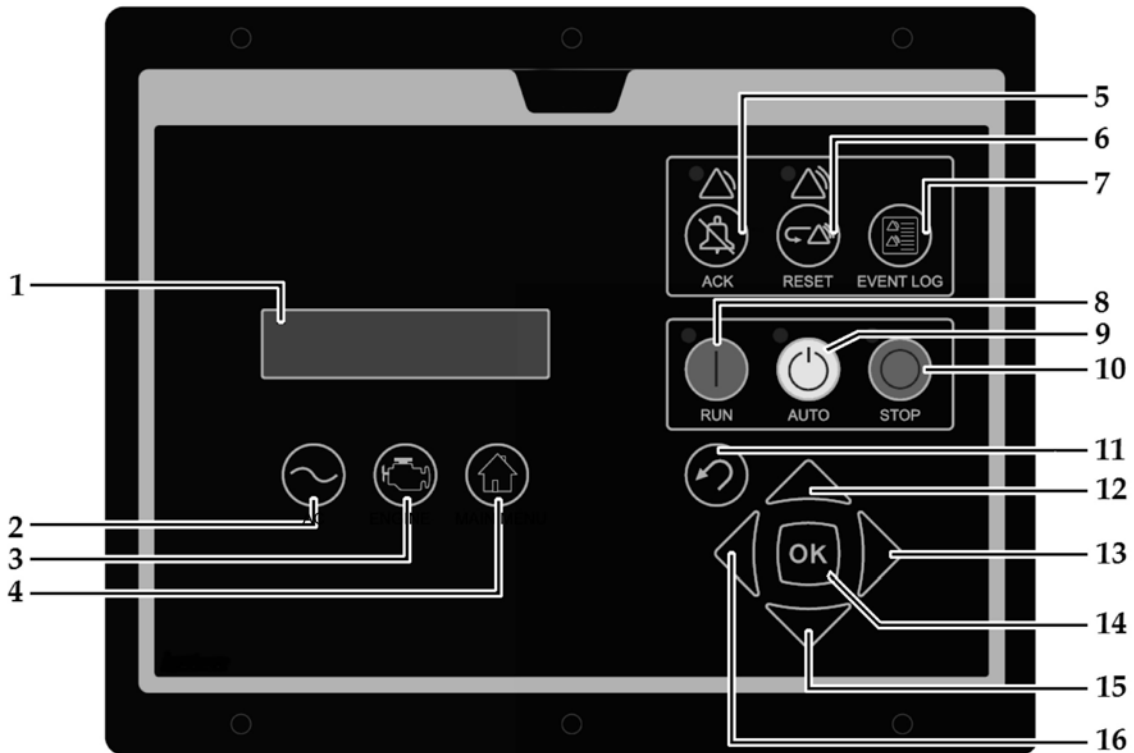

1. Display screen
2. AC overview key – The “AC OVERVIEW” key will navigate the display to the first screen of AC information. The “AC OVERVIEW” information contains various AC parameters that summarize the electrical operation of the generator set.
3. Engine overview key – The “ENGINE OVERVIEW” key will navigate the display to the first screen of engine information. The “ENGINE OVERVIEW” information contains various engine parameters that summarize the operation of the generator set.
4. Main menu key – The “MAIN MENU” key will navigate the display to the main menu directly without having to navigate out of menus.
5. Alarms acknowledge key – Pressing the “ACKNOWLEDGE” key will cause the horn relay to turn off. The horn relay being turned off will silence the horn. Pressing the “ACKNOWLEDGE” key will also cause any red or yellow flashing lights to either turn off or to come on continuously. The “ACKNOWLEDGE” key will also send out a global alarm silence signal on the J1939 Data Link. Annunciators on the J1939 Data Link can be configured to silence their individual horns upon receipt of the global acknowledge
6. Reset event key – Pressing the “RESET” key will reset all events that can be reset at this time. (Events that are PRESENT cannot be reset at this time.)
7. Event log – Pressing the “EVENT LOG” key will navigate the display to the event log.
8. Run key – Pressing the “RUN” key will put the generator set into a mode where it will attempt to start the engine, except in cases where there are any active or present shutdown events.
9. Auto key – pressing the “AUTO” key will cause the engine to enter the “AUTO” mode. The engine will start if the module receives a start command from a remote-start source..
10. Stop key – Pressing the “STOP” key will put the generator set into a mode where it will stop the engine. Depending on configuration, the set may run on for a cooldown period before stopping the engine.
11. Escape key – The “ESCAPE” key is used to navigate through the menus. When the key is pressed, the user moves backward or the user moves upward through the menus. The “ESCAPE” key is also used to exit out of entering data when the user is programming the setpoints. If the “ESCAPE” key is pressed while the user is programming the setpoints, changes made on the screen will not be saved to memory.
12. Up key – The “UP” key is used to navigate through the various menus and monitoring screens. The “UP” key is also used when a setpoint is entered. When entering numeric data, the “UP” key is used to increment the digits (0-9). If the setpoint requires selection from a list, the “UP” key is used to navigate UP through the list.
13. Right key – The “RIGHT” key is used during setpoint adjustment. The “RIGHT” key is used to select which digit is edited while entering numeric data. The “RIGHT” key is also used during some setpoint adjustments to select or to unselect a check box. If a check box has a check mark, the function has been enabled. Pressing the “RIGHT” key will disable the function. Pressing the

“RIGHT” key will also cause the check mark to disappear. If the check box does not have a check mark, the function is disabled. Pressing the “RIGHT” key will enable the function. Pressing the “RIGHT” key will also cause a check mark to appear.

14. OK/Enter key – The “ENTER” key is used to navigate through the menus. When the key is pressed, the user moves forward or the user moves downward through the menus. The “ENTER” key is also used to save any changes while the setpoints are being programmed. Pressing the “OK” key during programming the setpoints causes the changes to be saved to memory.
15. Down key – The “DOWN” key is used to navigate downward through the various menus or screens. The “DOWN” key is also used to program the setpoints. The “DOWN” key is used to decrease the digits when entering numeric data. If the setpoint requires selection from a list, the “DOWN” key is used to navigate DOWN through the list.
16. Left key – The “LEFT” key is used during setpoint adjustment. The “LEFT” key is used to select the digit that is edited during the entry of numeric data. The “LEFT” key is also used during some of the setpoint adjustments to select a check box. The key is also used to unselect a check box. If a check box has a check mark, pressing the “LEFT” key will disable the function. Pressing the key will also remove the check mark. Pressing the “LEFT” key will also cause the check mark to disappear. If the check box does not have a check mark, pressing the “LEFT” key will enable the function. Pressing the “LEFT” key will also cause a check mark to appear.

Alarm Indicators

Yellow Warning Lamp – A yellow warning lamp is located above the “ACKNOWLEDGE” key. A flashing yellow light indicates that there are active warnings that have not been acknowledged. A continuous yellow light indicates that there are acknowledged warnings that are active. If there are any active warnings, the yellow light will change from flashing yellow to continuous yellow after the “ACKNOWLEDGE” key is pressed. If there are no longer any active warnings, the yellow light will turn off after the “ACKNOWLEDGE” key is pressed.

Red Shutdown Lamp – A red shutdown lamp is located above the “RESET” key. A flashing red light indicates that there are active shutdowns that have not been acknowledged. A continuous red light indicates that there are active shutdowns that have been acknowledged. If there are any active shutdowns, the red light will change from flashing red to continuous red after the “ACKNOWLEDGE” key is pressed. Any condition that has caused a shutdown must be manually reset. If there are no longer any active shutdowns, the red light will turn off.

5.3.2 PowerWizard 4.1 Control Module Description

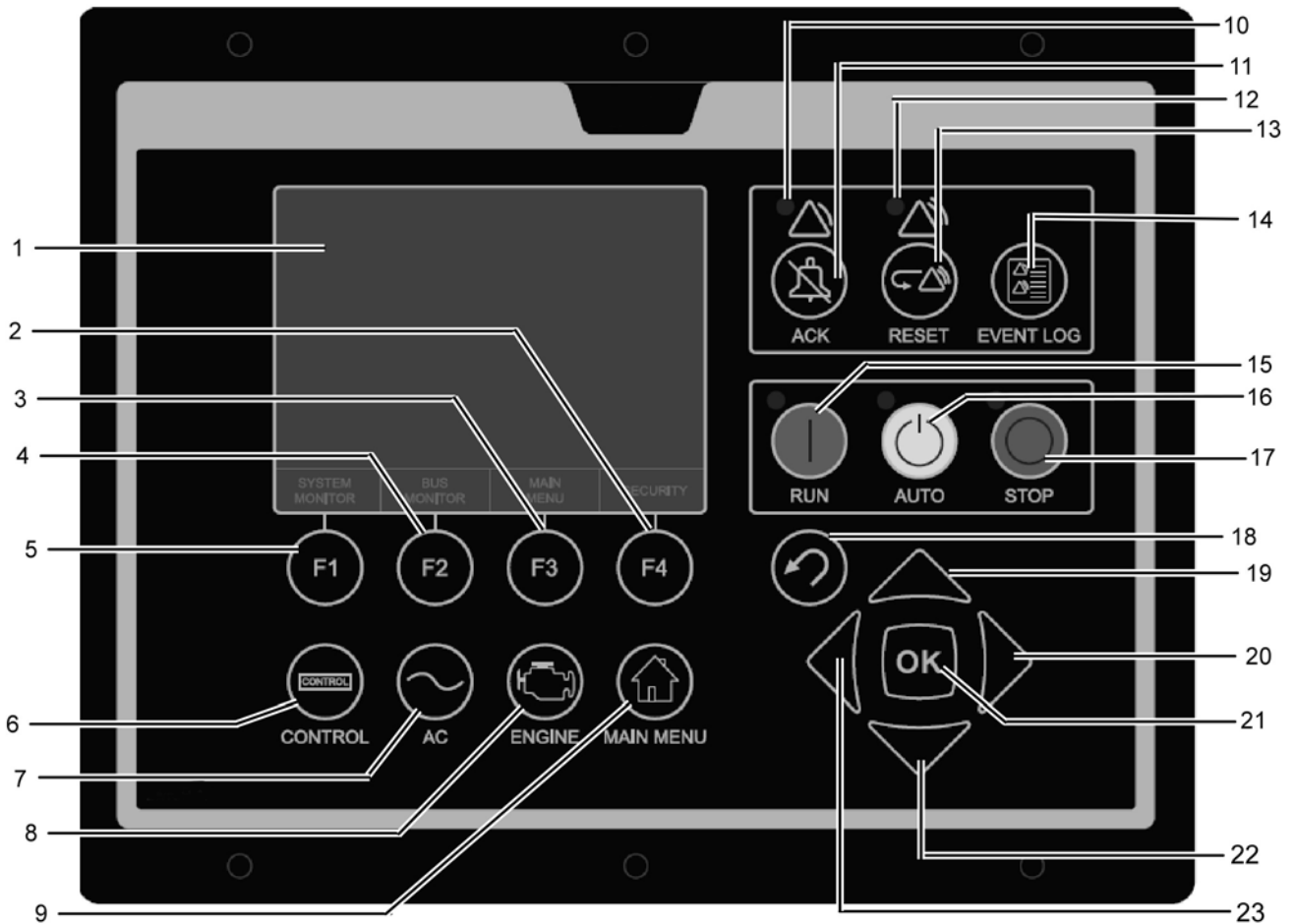

1. Display screen –
2. F4 Soft key – The function of the “F4” soft key can change depending on which screen is active. The space at the bottom of the screen immediately above each soft key displays what the function of that soft key will be.
3. F3 Soft key – The function of the “F3” soft key can change depending on which screen is active. The space at the bottom of the screen immediately above each soft key displays what the function of that soft key will be.
4. F2 Soft key – The function of the “F2” soft key can change depending on which screen is active. The space at the bottom of the screen immediately above each soft key displays what the function of that soft key will be.
5. F1 Soft key – The function of the “F1” soft key can change depending on which screen is active. The space at the bottom of the screen immediately above each soft key displays what the function of that soft key will be.
6. Control key – The “CONTROL” key will navigate the display to the control menu.
7. AC overview key – The “AC OVERVIEW” key will navigate the display to the first screen of AC information. The “AC OVERVIEW” information contains various AC parameters that summarize the electrical operation of the generator set.
8. Engine overview key – The “ENGINE OVERVIEW” key will navigate the display to the first screen of engine information. The “ENGINE OVERVIEW” information contains various engine parameters that summarize the operation of the generator set.
9. Main menu key – The “MAIN MENU” key will navigate the display to the main menu directly without having to navigate out of menus.
10. Warning indicator lamp (yellow) – A yellow warning lamp is located above the “ACKNOWLEDGE” key. A flashing yellow light indicates that there are active warnings that have not been acknowledged. A continuous yellow light indicates that there are acknowledged warnings that are active. If there are any active warnings, the yellow light will change from flashing yellow to continuous yellow after the “ACKNOWLEDGE” key is pressed. If there are no longer any active warnings, the yellow light will turn off after the “ACKNOWLEDGE” key is pressed.
11. Alarms acknowledge key and silence key – Pressing the “ACKNOWLEDGE” key will cause the horn relay to turn off. The horn relay being turned off will silence the horn. Pressing the “ACKNOWLEDGE” key will also cause any red or yellow flashing lights to either turn off or to come on continuously. The “ACKNOWLEDGE” key will also send out a global alarm silence signal on the J1939 Data Link. Annunciators on the J1939 Data Link can be configured to silence their individual horns upon receipt of the global acknowledge.
12. Shutdown indicator lamp (red) – A red shutdown lamp is located above the “RESET” key. A flashing red light indicates that there are active shutdowns that have not been acknowledged. A continuous red light indicates that there are active

shutdowns that have been acknowledged. If there are any active shutdowns, the red light will change from flashing red to continuous red after the "ACKNOWLEDGE" key is pressed. Any condition that has caused a shutdown must be manually reset. If there are no longer any active shutdowns, the red light will turn off.

13. Event reset key – Pressing the "RESET" key will reset all events that can be reset at this time. (Events that are PRESENT cannot be reset).
14. Event log key – Pressing the "EVENT LOG" key will navigate the display to the event log.
15. Run key – Pressing the "RUN" key will put the generator set into a mode where it will attempt to start the engine, except in cases where there are any active or present shutdown events.
16. Auto key – Pressing the "AUTO" key will cause the engine to enter the "AUTO" mode. The engine will start if the module receives a start command from a remote-start source.
17. Stop key – Pressing the "STOP" key will put the generator set into a mode where it will stop the engine. Depending on configuration, the set may run on for a cooldown period before stopping the engine.
18. Escape key – The "ESCAPE" key is used to navigate through the menus. When the key is pressed, the user moves backward or the user moves upward through the menus. The "ESCAPE" key is also used to exit out of entering data when the user is programming the setpoints. If the "ESCAPE" key is pressed while the user is programming the setpoints, changes made on the screen will not be saved to memory.
19. Up key – The "UP" key is used to navigate through the various menus and monitoring screens. The "UP" key is also used when a setpoint is entered. When entering numeric data, the "UP" key is used to increment the digits (0-9). If the setpoint requires selection from a list, the "UP" key is used to navigate UP through the list.
20. Right key – The "RIGHT" key is used during setpoint adjustment. The "RIGHT" key is used to select which digit is edited while entering numeric data. The "RIGHT" key is also used during some setpoint adjustments to select or to unselect a check box. If a check box has a check mark, the function has been enabled. Pressing the "RIGHT" key will disable the function. Pressing the "RIGHT" key will also cause the check mark to disappear. If the check box does not have a check mark, the function is disabled. Pressing the "RIGHT" key will enable the function. Pressing the "RIGHT" key will also cause a check mark to appear.
21. OK/Enter key – The "ENTER" key is used to navigate through the menus. When the key is pressed, the user moves forward or the user moves downward through the menus. The "ENTER" key is also used to save any changes while the setpoints are being programmed. Pressing the "OK" key during programming the setpoints causes the changes to be saved to memory.
22. Down key – The "DOWN" key is used to navigate downward through the various menus or screens. The "DOWN" key is also used to program the setpoints. The "DOWN" key is used to decrease the digits when entering numeric data. If the setpoint requires selection from a list, the "DOWN" key is used to navigate DOWN through the list.
23. Left key – The "LEFT" key is used during setpoint adjustment. The "LEFT" key is used to select the digit that is edited during the entry of numeric data. The "LEFT" key is also used during some of the setpoint adjustments to select a check box. The key is also used to unselect a check box. If a check box has a check mark, pressing the "LEFT" key will disable the function. Pressing the key will also remove the check mark. Pressing the "LEFT" key will also cause the check mark to disappear. If the check box does not have a check mark, pressing the "LEFT" key will enable the function. Pressing the "LEFT" key will also cause a check mark to appear.

5.3.3 Alarm Log and Resetting

Note:

- To reset the menu back to the event log menu, please press the "Event Log" key.

Event Viewing

There are two ways to view events. Pressing the "EVENT LOG" key navigates directly to the "ACTIVE EVENTS" menu. The other way is to use the Main Menu:

1. From the MAIN MENU/VIEW, highlight "EVENT LOGS" and press the "Enter" key. The "ACTIVE EVENTS" menu will be displayed in this menu.
2. In order to scroll through the events use the up and down keys. Events are ordered with present events first, active events next and inactive events last. Within these classifications they are ordered by the real time clock at the time of the event.
3. Press "Enter" after highlighting an event to see additional information such as SPN, FMI, time and date of first occurrence, time and date of last occurrence, engine hours at first occurrence and engine hours at last occurrence.

Quick Shut Down Resetting

In addition to the above procedure there is also a simplified process for resetting all events. To reset all events:

1. Ensure that the control is in the stopped position.
2. Press the "Reset Event" key from any screen.
3. A confirmation prompt will appear.
4. Press the "OK" key to reset all events on all modules. Press the 'ESCAPE' key to cancel the reset operation.

Note:

- The PowerWizard must be in stop mode to reset events.

Present events cannot be reset.

Shut Down Resetting

A flashing red shutdown light indicates there is an unacknowledged shutdown event. The red shutdown light will change from flashing red to solid red when the Alarm Acknowledged key is pressed. Once a fault has been checked and the cause rectified, use the following procedure in order to reset the event:

1. Press the "Stop" key.
2. Enter the "EVENT LOGS" option from the main menu.
3. Select a "Module" from the list.
4. Scroll through the events in order to highlight the event to be reset.
5. Make sure the event status is active (not present).
6. Press the "Enter" key.
7. "RESET" will be highlighted if the condition is no longer present and the control is in stop.
8. Press the "Enter" key again. The fault will clear.
9. Press the "Escape" or "Main Menu" key in order to get back to the main menu.

5.3.4 Security

There are 3 levels of password protection on the PowerWizard control panel. All of the adjustable setpoints are associated with a specific level of security required to make an adjustment to the parameter. The passwords only affect changing setpoints within the control panel.

The level of password protection that is required for each setpoint is identified on the parameter setpoint entry screen. A security level identification number "1", "2" or "3" next to a padlock symbol is displayed on the parameter setpoint entry screen. A Level 3 security is used for the most secure setpoints and Level 1 security is used for the least secure setpoints. If the PowerWizard is currently at the required level of protection when viewing a parameter, the padlock will not appear.

If a parameter is displayed with a padlock but no security level identification number next to it, the parameter cannot be changed from the PowerWizard display and the Dealer must be contacted. Level 1 and 2 passwords are disabled when installed. Level 1 and 2 passwords are user level passwords and can be used if desired.

The PowerWizard 2.1 also has a SCADA password, which can be used to secure remote communications.

To view the security menu:

MAIN MENU > CONFIGURE > SECURITY.

At the top of the security menu the current security level is displayed. Within the security menu are the following options:

DROP TO MINIMUM LEVEL – used to return the current security level to the lowest level set-up. Highlight and press Enter to drop to minimum security level. If no Level 1 or 2 passwords are set-up the minimum level will be 2. If a Level 2 password is set-up, the minimum level will be 1 and if a Level 1 password is set-up the minimum level will be 0.

ENTER LEVEL 1 OR 2 – used to enter Level 1 or 2 passwords. Highlight and press Enter to proceed to the password entry screen. Passwords can be entered using the cursor keys. In PowerWizard, Level 1 and 2 passwords must be different. An entered password is compared against the stored Level 1 and 2 passwords, if the password is correct the PowerWizard will go to the corresponding security level.

ENTER LEVEL 3 – used to obtain Level 3 access. The Level 3 security password is reserved for critical setpoints that should only be changed by a skilled operative. As such you must contact your Dealer if you require a change associated with a Level 3 password.

CHANGING LEVEL 1 PASSWORD – used to set-up, change or disable a Level 1 password. In order to use this feature the control must be at current security Level 1 or higher. Highlight and press Enter to proceed to the password entry screen. To set-up or change the password, enter the new password using the cursor keys. Passwords may be 16 digits long. To disable the Level 1 security password, set the password to '0'. Press the Enter key to save.

CHANGING LEVEL 2 PASSWORD – used to set-up, change or disable a Level 2 password. In order to use this feature the control must be at current security Level 2 or higher. Highlight and press Enter to proceed to the password entry screen. To set-up or change the password, enter the new password using the cursor keys. Passwords may be 16 digits long. To disable the Level 2 security password, set the password to '0'. Press the Enter key to save.

CHANGING SCADA PASSWORD – used to set-up, change or disable a SCADA password. Highlight and press enter to proceed to the password entry screen. To set-up or change the password, enter the new password using the cursor keys. Passwords may be 16 digits long. To disable the SCADA security password, set the password to '0'. Press the Enter key to save.

5.3.5 Real Time Clock Programming

The real time clock provides information for the time and date of an automatic time based start/stop control. It also provides a mechanism for time stamps in the event log. The real time clock is not calibrated and is for information only. The date and time are set by the user.

1. In order to set the time or date format:
MAIN MENU > CONFIGURE > TIME/DATE.
2. To set the time, highlight the time then press the "Enter" key twice.
3. Use the cursor keys to set the time and press the "Enter" key to save. Press the "Escape" key to return.
4. To set the date, highlight the date then press the "Enter" key twice.
5. Use the cursor keys to set the date and press the "Enter" key to save. Press the "Escape" key to return.
6. To set the date format, highlight either the FORMAT DD/MM/YY or FORMAT MM/DD/YY and press the "Enter" key.
7. Use the cursor keys to select the required date format and press the "Enter" key to save.

5.3.6 Fuel Transfer

Fuel pump in connection with fuel level measurement can be controlled to transfer diesel to the fuel tank.

1. In order to set the Fuel Transfer operation:
MAIN MENU > CONTROL > FUEL TRANSFER
2. To start or stop the fuel pump, highlight the PUMP CONTROL then press the "OK" key.
3. Use the cursor key to select START FUEL PUMP or STOP FUEL PUMP and press the "OK" key.
4. Auto Fuel Load Pump On and Off thresholds are set at 25% and 75% respectively.

5.3.7 Additional Features Available

Reduced Power Mode

The reduced power mode must be set when the generator set is not running

After a configurable period of inactivity the control will go into Reduced Power Mode to minimise current drain on the battery. When in Reduced Power Mode the display will be blank and any active LEDs will blink briefly every second or so rather than be on solid. Pressing any key will bring the panel out of Reduced Power Mode. For further information please consult your local dealer.

Remote Annunciation of Faults

The PowerWizard Annunciator is used in remote applications, mounted separately from the generator set to provide remote indication of system operating and alarm conditions.

For further information on these features, please contact your Dealer.

5.3.8 Trouble Shooting Guide for PowerWizard

Fault	Symptom	Remedy
Engine fails to start	Engine does not crank when start signal is given, either manually via run key or automatically via a remote signal	<ol style="list-style-type: none"> 1. Check all emergency stop push buttons are released 2. Check the stop button light is not on 3. Check there are no shutdown events active. Reset, if required, after remedying the indicated fault 4. Refer to your local dealer
Engine stops due to low oil pressure	"LOW OIL PRESSURE" in event log. Red shutdown led illuminates	<ol style="list-style-type: none"> 1. Check oil level 2. Refer to your local dealer
Engine stops due to high coolant temp	"HIGH COOLANT TEMP" in event log. Red shutdown led illuminates	<ol style="list-style-type: none"> 1. Check coolant level in the radiator. Refer to safety section before removing the radiator cap 2. Refer to your local dealer
Engine stops due to overspeed	"OVERSPEED" in event log. Red shutdown led illuminates	<ol style="list-style-type: none"> 1. Verify the actual engine speed 2. Refer to your local dealer
Engine stops due to under-voltage	"UNDER-VOLTAGE" in event log, red shutdown led illuminates	<ol style="list-style-type: none"> 1. Refer to your local dealer
Engine stops due to over-voltage	"Over-voltage" in event log, red shutdown led illuminates	<ol style="list-style-type: none"> 1. Refer to your local dealer
Generator set does not go on load	Generator set is running but the load is not being powered	<ol style="list-style-type: none"> 1. Refer to your local dealer
Generator set does not stop manually	Generator set keeps running after being switched off	<ol style="list-style-type: none"> 1. Check via the engine Overview screen if the generator is in cooldown. 2. If the genetator does not stop after cooldown (typically 3 minutes) refer to local dealer.
Generator set does not stop when in auto mode	Generator set does not stop after remote start signal is removed	<ol style="list-style-type: none"> 1. Check there is no remote start signal via digital input 2. Check there is no remote start signal from the timeclock 3. Check there is no remote signal via Modbus remote communication 4. Check there is no remote start signal from the PLC logic. 5. On PowerWizard 4.1 the set could also be getting a remote start signal across the Multiple Genset DataLink 6. Check the generator set stops when changed from Auto to Stop.
Alarm for not in auto mode (standby sets)	"Not in auto mode" alarm in event log, amber led illuminates	<p>To enabled / disable navigate as follows:</p> <ol style="list-style-type: none"> 1. Main Menu -> Configure -> All setpoints -> Events -> Other System Config. 2. Scroll down to "Gen Control Not in Auto Warning Config". 3. Use the right key to select Edit and press enter. 4. Use the left key to turn off a response. Press enter to keep your selection. <p>Note: the set must be in Stop to edit an event respone configuration.</p>

5.4 DCP-10 & DCP-20

5.4.1 General Information



Figure 5.7 – DCP-10 and DCP-20 Control Panels

Illustrated above are the Automatic Start Control Modules (DCP-10 & DCP-20) designed to automatically start and stop the generator set.

The modules also monitor and protect the engine, indicating operational status, fault conditions and metering on the front panel LCD and LED's.

5.4.2 DCP Control Module Description

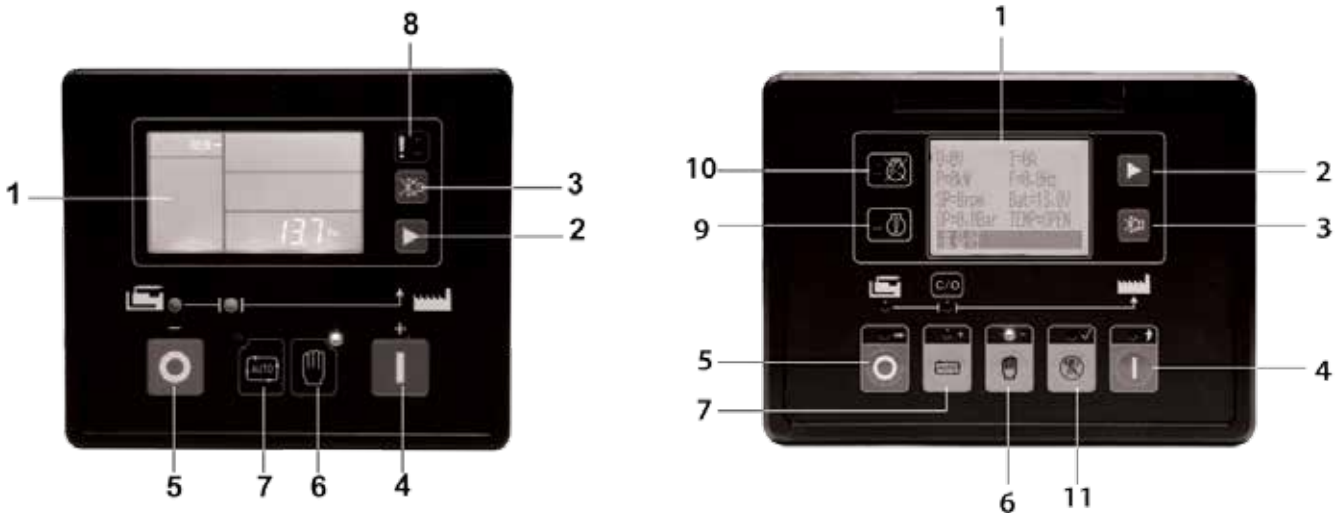

Figure 5.8 – DCP-10 and DCP-20 Control Module Description

1. Display Screen
2. Scroll Button – Scroll menu, Enter into or exit configuration menu
3. Mute\Lamp Test – For Lamp test press and hold for 2 secs
4. Start Button
5. Stop Button
6. Manual Mode
7. Auto Mode
8. Common Failure LED (DCP-10 Only) – Flashes when Warning occurs, Illuminates permanently when shutdown occurs.
9. Warning LED (DCP-20 Only) – Illuminates permanently until the warning is rectified then automatically turns off.
10. Shutdown LED (DCP-20 Only) – Illuminates permanently shutting engine down
11. Test Mode

5.4.3 Basic Operation

START Mode



Press START Key

Figure 5.9 - Basic Operation Start Key

STOP Mode



Press STOP Key

Figure 5.10 - Basic Operation Stop Key

AUTO Mode



Press AUTO Key
(An LED will illuminate to show Auto Mode)

Figure 5.11 - Basic Operation Auto Key

MANUAL Mode



Press MANUAL Key
(An LED will illuminate to show Manual Mode)

Figure 5.12 - Basic Operation Manual Key

5.4.4 Fault / Alarm Reset Process - DCP-10

Alarm / Shutdown

Whenever a warning occurs the LED indicator will flash, but the generator set will not shut down.

Once the issue is resolved the Warning LED will automatically turn off.

Whenever a shutdown occurs the LED indicator illuminates.. The system is immediately locked out and the generator set stops.

This fault can be reset by pressing the STOP Key. This clears the fault, the LED indicator extinguishes and the generator set is no longer locked out and can be started.



5.4.5 Fault / Alarm Reset Process - DCP-20

Alarm

Whenever a warning occurs the LED indicator illuminates permanently, but the unit will not shut down.

Once the warning is removed or rectified the Warning LED will automatically turn off.

Shutdown

Illuminates permanently when shutdown alarm occurs.

Whenever a shutdown occurs the LED indicator illuminates permanently. The system is immediately locked out and the generator set stops.

This Fault can be reset by pressing the STOP Key. This clears the fault, the LED extinguishes and the generator set is no longer locked out and can be started.



5.4.6 User Interface Overview

Before starting or running the generator set, the operator should become fully acquainted with the control module's display and push buttons. The display should be observed from time to time while the generator set is running so that any abnormal readings can be detected before problems arise. Addition of optional equipment may add items, so that the panel fitted on the generator set may be slightly different from the typical one shown. The following descriptions explain the function of each standard item on the panels:

Function Keys:

 Scroll Button – The scroll button will allow the user to navigate through the various screens and parameters available to them.

Control Keys:

 RUN – pressing the Run key will cause the engine to enter the run mode.

 AUTO – pressing the Auto key will cause the engine to enter the auto mode.

 MANUAL – pressing the Manual key will cause the engine to enter manual mode.

Navigation Keys – DCP-10

 When in parameter setting mode this button is used to increase values.

 When in parameter setting mode this button is used to decrease values.

 When in parameter setting mode this button will confirm any changes and also exit the configuration menu.

Navigation Keys – DCP-20



When in parameter setting mode this button is used to increase value/scroll down menu.



When in parameter setting mode this button is used to decrease value/scroll up menu.



When in parameter setting mode this button is used to enter into submenu/confirm modification.



When in parameter setting mode this button is used to return to the upper menu.



When in parameter setting mode this button is used to modify the next value.



Used to enter or exit parameter settings, by pressing and holding for 2 seconds.

Event Keys and Indicators:



Mute Button – When a failure occurs the alarm buzzer sounds. Pressing the Mute Button will mute the buzzer and the LCD will display the Mute Icon.



Stop Button – Whenever the generator set is at rest pressing the stop button will reset any alarms that have occurred. It will not reset any active events. If a warning or shutdown occurs either text or a symbol will appear on the display indicating what the event is. Please refer to the relevant technical manual for the controller for an accurate description of these events.

Display Preferences for DCP-10 Panel

Pressing any push button will illuminate the backlight and will automatically turn off after a preset time. In normal operating status, you can set the page scroll time to scroll through each screen automatically. Press the scroll button to manually scroll through each screen. When a failure occurs, the LCD displays the corresponding failure icon.

Whenever the controller is in standby the following data is displayed:

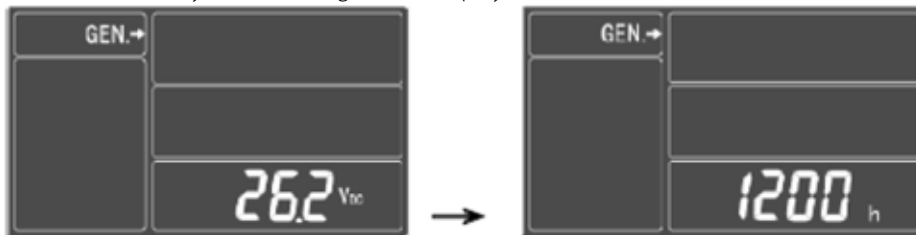







When the controller is running normally it cycles through the following data:



Display Preferences for DCP-20 Panel

Each page can display multi-row information simultaneously. Pressing  will allow the user to scroll to the next page. The display can also be configured to scroll automatically. When an alarm occurs, the alarm is displayed on the LCD immediately.

When the Generator set is running the LCD scrolls through the screens showing the following data –

operation	Description	
<p>The voltage/current value displayed on this screen is the average value of 3 phases. Press "" to scroll to the next page.</p>	U=380V	I=0A
	P=0kW	F=50.0Hz
	SP=1500rpm	Bat=25.4V
	OP=4.6Bar	TEMP=70°C
	RUN	
<p>This page displays electrical parameters for L1. Press "" to scroll to the next page.</p>	V1=220V	U12=380V
	I1=0A	A1=0kVA
	P1=0kW	PF1=1.00
	Q1=0kVAr	
	RUN	
<p>This page displays electrical parameters for L2. Press "" to scroll to the next page.</p>	V2=220V	U23=380V
	I2=0A	A2=0kVA
	P2=0kW	PF2=1.00
	Q2=0kVAr	
	RUN	
<p>This page displays electrical parameters for L3. Press "" to scroll to the next page.</p>	V3=220V	U31=380V
	I3=0A	A3=0kVA
	P3=0kW	PF3=1.00
	Q3=0kVAr	
	RUN	
<p>This page displays Gen power and average power factor. Press "" to scroll to the next page.</p>	G. P=0kW	
	G. A=0kVA	
	G. Q=0kVAr	
	G. PF=1.00	
	RUN	
<p>This page displays running hours, crank attempt and auxiliary sensor level. Press "" to scroll to the next page.</p>	Run Hours = 0.0	
	Counters = 0	
	Fuels = 46%	Heat = 40°C
	RUN	
<p>This page displays total active and reactive energy. Press "" to scroll to the next page.</p>	G. kWhr = 0	
	G. kVArHr = 0	
	RUN	
<p>Relay Outputs refer to the status of configurable relay output. Digital Inputs refer to the status of configurable inputs. "0" indicates an active Output or Input. Press "" to scroll to the next page.</p>	Relay Outputs:	
	--- 0 ----	
	Digital Inputs:	
	---- -- 0 -	
	RUN	

5.5 DeepSea Controller

5.5.1 Description



1. Stop / Reset Mode

This button places the module into its Stop/Reset Mode. This will clear any alarm conditions for which the triggering criteria have been removed. If the engine is running and the module is put into Stop mode, the module will automatically instruct the generator to unload ('Close Generator' and 'Delayed Load Output 1, 2, 3 & 4' become inactive (if used)). The fuel supply de-energises and the engine comes to a standstill. Should any form of remote start signal be present while operating in this mode, a start will not occur.

2. Auto Mode

This button places the module into its Auto Mode. This mode allows the module to control the function of the generator automatically. The module will monitor the remote start input and battery charge status and once a start request is made, the set will be automatically started and placed on load ('Close Generator' and 'Delayed Load Output 1, 2, 3 & 4' become active in order from lowest to highest (if used)).

Upon removal of the starting signal, the module will remove the load from the generator and shut the set down observing the stop delay timer and cooling timer as necessary ('Close Generator' and 'Delayed Load Output 1, 2, 3 & 4' become inactive at once (if used)). The module will then await the next start event.

3. Manual / Start Mode

This button will start the engine and run off load. To place the generator on load, digital inputs are required to be assigned to perform this function. If the engine is running off-load in Manual/Start Mode button and a remote start signal becomes present, the module will automatically instruct the changeover device to place the generator on load ('Close Generator' and 'Delayed Load Output 1, 2, 3 & 4' becomes active (if used)). Upon removal of the Remote Start Signal, the generator remains on load until either selection of the Stop/Reset Mode or Auto Mode.

4. Menu Navigation

Used for navigating the instrumentation, event log and configuration screens. For further details, please see the more detailed description of these items elsewhere in this manual.

5.5.1 Alarm Icons

An icon is displayed in the Alarm Icon section to indicate the alarm that is current active on the controller. In the event of a warning alarm, the LCD only displays the Alarm Icon. In the event of an electrical trip or shutdown alarm, the module displays the Alarm Icon and the Stop/Reset Mode button LED begins to flash.

If multiple alarms are active at the same time, the Alarm Icon automatically cycles through all the appropriate icons to indicate each alarm which is active.

Warnings are non-critical alarm conditions and do not affect the operation of the generator system, they serve to draw the operators attention to an undesirable condition. By default, warning alarms are self-resetting when the fault condition is removed. However enabling 'all warnings are latched' will cause warning alarms to latch until reset manually. This is enabled using the DSE Configuration Suite in conjunction with a compatible PC.

5.5.2 Electrical Trip Alarm Icons

Electrical trips are latching and stop the Generator but in a controlled manner. On initiation of the electrical trip condition the module de-energises all the 'Delayed Load Output' and the 'Close Gen Output' outputs to remove the load from the generator. Once this has occurred the module starts the Cooling timer and allows the engine to cool off-load before shutting down the engine. The alarm must be accepted and cleared, and the fault removed to reset the module. Electrical trips are latching alarms and to remove the fault, press the Stop/Reset Mode button on the module.

5.5.3 Stop/Reset Mode

NOTE: If a digital input configured to panel lock is active, changing module modes will not be possible. Viewing the instruments and event logs is NOT affected by panel lock.

Stop/Reset Mode is activated by pressing the Stop/Reset Mode button. The Stop/Reset icon is displayed to indicate Stop/Reset Mode operations. In Stop/Reset Mode, the module removes the generator from load (if necessary) before stopping the engine if it is already running. If the engine does not stop when requested, the FAIL TO STOP alarm is activated (subject to the setting of the Fail to Stop timer).

To detect the engine at rest the following must occur :

- Engine speed is zero as detected by the CANbus ECU
- Generator AC Voltage and Frequency must be zero.
- Engine Charge Alternator Voltage must be zero.
- Oil pressure sensor must indicate low oil pressure

When the engine has stopped, it is possible to send configuration files to the module from DSE Configuration Suite PC software and to enter the Front Panel Editor to change parameters. Any latched alarms that have been cleared are reset when Stop/Reset Mode is entered. The engine is not started when in Stop/Reset Mode. If remote start signals are given, the input is ignored until Auto Mode is entered.

When left in Stop/Reset Mode with no presses of the fascia buttons and configured for 'Power Save Mode', the module enters Power Save Mode. To 'wake' the module, press any fascia control buttons or activate Digital Input A. The same is true for Deep Sleep Mode.

5.5.4 Fault Finding

Symptom	Possible Remedy
Unit is inoperative Read/Write configuration does not operate	Check the battery and wiring to the unit. Check the DC supply. Check the DC fuse.
Unit shuts down	Check DC supply voltage is not above 35 Volts or below 9 Volts Check the operating temperature is not above 70°C. Check the DC fuse.
Fail to Start is activated after pre-set number of attempts to start	Check wiring of fuel solenoid. Check fuel. Check battery supply. Check battery supply is present on the Fuel output of the module. Check the speed-sensing signal is present on the module's inputs. Refer to engine manual.
Continuous starting of generator when in the <i>Auto Mode</i> 	Check that there is no signal present on the "Remote Start" input. Check configured polarity is correct. Check the mains supply is available and within configured limits
Generator fails to start on receipt of Remote Start signal.	Check Start Delay timer has timed out. Check signal is on "Remote Start" input. Confirm correct configuration of input is configured to be used as "Remote Start". Check that the oil pressure switch or sensor is indicating low oil pressure to the controller. Depending upon configuration, then set will not start if oil pressure is not low.
Pre-heat inoperative	Check wiring to engine heater plugs. Check battery supply. Check battery supply is present on the Pre-heat output of module. Check pre-heat configuration is correct.
Starter motor inoperative	Check wiring to starter solenoid. Check battery supply. Check battery supply is present on the Starter output of module. Ensure oil pressure switch or sensor is indicating the "low oil pressure" state to the controller.

Symptom	Possible Remedy
Engine runs but generator will not take load	Check Warm up timer has timed out. Ensure generator load inhibit signal is not present on the module inputs. Check connections to the switching device. Note that the set will not take load in manual mode unless there is an active load signal.
Incorrect reading on Engine gauges Fail to stop alarm when engine is at rest	Check engine is operating correctly. Check that sensor is compatible with the module and that the module configuration is suited to the sensor.

Symptom	Possible Remedy
Low oil Pressure fault operates after engine has fired	Check engine oil pressure. Check oil pressure switch/sensor and wiring. Check configured polarity (if applicable) is correct (i.e. Normally Open or Normally Closed) or that sensor is compatible with the module and is correctly configured.
High engine temperature fault operates after engine has fired.	Check engine temperature. Check switch/sensor and wiring. Check configured polarity (if applicable) is correct (i.e. Normally Open or Normally Closed) or that sensor is compatible with the module.
Shutdown fault operates	Check relevant switch and wiring of fault indicated on LCD display. Check configuration of input.
Electrical Trip fault operates	Check relevant switch and wiring of fault indicated on LCD display. Check configuration of input.
Warning fault operates	Check relevant switch and wiring of fault indicated on LCD display. Check configuration of input.
CAN ECU WARNING CAN ECU SHUTDOWN	This indicates a fault condition detected by the engine ECU and transmitted to the DSE controller.
CAN DATA FAIL	Indicates failure of the CAN data link to the engine ECU. Check all wiring and termination resistors (if required).
Incorrect reading on Engine gauges	Check engine is operating correctly. Check sensor and wiring paying particular attention to the wiring to terminal 10 <input type="text"/>
Fail to stop alarm when engine is at rest	Check that sensor is compatible with the module and that the module configuration is suited to the sensor.

5.6 Control System Options and Upgrades

A large variety of options may be fitted to customise the control system to a specific installation. The following sections cover the use and operation of some of these options.

- ⚠ **To ensure safe operation in the instance where a generator set is ordered and supplied without a factory fitted control panel, the operator should ensure a compliant** control panel has been connected and tested by an official FG Wilson Dealer prior to generator set operation.**

(Compliance requirements may vary. All local and application specific requirements should be adhered to.)**

5.6.1 Battery Trickle / Auto Boost Chargers

Both battery chargers are designed to ensure that the starter batteries maintain their charge even if the generator set is not operated for long periods.

Control switches for the chargers are not normally fitted to prevent inadvertently switching off the charger.

The control system will not disconnect the charger on startup of the generator set, it will remain in an active state at all times. While the engine is running the batteries are charged by the engine driven battery charging alternator.

The switch-mode charger is an automatic battery charger, switch mode chargers with Auto Boost will automatically enter an increased charging voltage state (boost) when the voltage drops below a preset voltage level. After the auto boost cycle the charger will switch back to its normal 'float' voltage. This prevents the battery from over charging, which in turn prevents over gassing and subsequently maximises battery life.

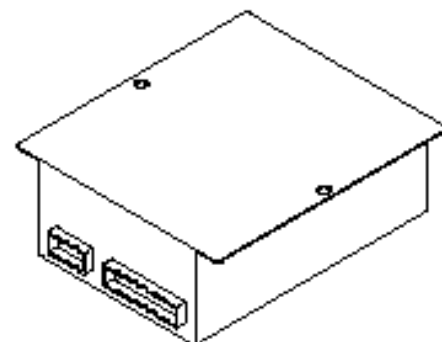

Figure 5.15 – Battery Charger

5.6.2 Heaters

Immersion type heaters (engine heaters) may be fitted in the engine coolant system to ensure that the engine is easy to start and able to take load more quickly.

Alternator anti-condensation heaters (alternator heaters) may be fitted to the alternator stator winding to keep them dry in humid conditions.

Panel anti-condensation heaters (panel heaters) may be fitted in the control panel to keep moisture levels down.

Control switches are not normally fitted but may be fitted as an additional option. With or without control switches, the heaters are automatically disconnected on engine start up.

5.6.3 Electric Fuel Transfer Pumps

Fuel transfer pumps are required when fuel must be transferred from a bulk storage tank to the generator set day tank.

The controls consist of two illuminated push buttons on the control panel door or separate box under the panel. The red button is a combined trip lamp and stop button. The green button is a run lamp and manual start push button.

To operate the pump manually, ensure the red push button is in the "ON" position (pulled out). Press and hold the green push button to manually run the pump. The pump will only run in the manual mode while the green button is held in.

To operate the pump in automatic mode, ensure that the red push button is in the "ON" position (pulled out). The pump will start running automatically when the fuel level is low and will illuminate the green run lamp. When the tank is full, the pump is turned off and the green lamp is extinguished.

The red lamp will illuminate if there has been an electrical overload.

Care must be taken to ensure that the pump is primed with fuel prior to operation to lubricate the seals. Also, the pump should never be run when the bulk tanks are empty or when valves on the fuel fill lines are closed.

5.6.4 Meters / Gauges

The following additional meters or gauges may be fitted to the control panel:

- Three ammeters mounted on the panel instead of one ammeter and a selector switch. This allows a continuous indication of the current flowing in each phase, not applicable for PowerWizard as this module will display all phase currents. (Not applicable to 26 – 220 kVA product).
- Kilowatt (kW) Meter to provide accurate readings of the load being supplied by the generator set, not applicable for PowerWizard as the PowerWizard 2.1 can display kilowatts.
- Lube Oil Temperature Gauge to monitor the lubricating oil temperature when the engine is operating. The normal operating temperature should be approximately 90° – 110°C (195° – 230°F), not applicable for PowerWizard 1.1 and 2.1+ as the modules will display this.
- Ammeter for Battery Trickle Charger to monitor the current flow to the battery. It is used to observe the charging current being supplied by the battery trickle charger. When the batteries are fully charged this current will be small (less than 5 Amps) but with a partially discharged battery this current may be as high as 40 Amps.

5.6.5 Speed / Voltage Control

Three controls may be fitted to adjust the speed or voltage of the generator set: Speed Adjust Potentiometer, a Raise/Lower Switch and a Voltage Adjust Potentiometer. These should only be adjusted by a qualified generator set technician according to instructions in the Technical Manual. For some electronic engines, speed can be adjusted on the PowerWizard 2.1+ module.

5.6.6 Alarm Signalling

Four options may be fitted to the control panel to supplement the standard alarm indications of the alarm lamps:

- A panel mounted alarm siren will sound when an alarm condition is indicated. An Alarm Mute push button is fitted on the panel to silence the siren.
- An audible alarm siren supplied loose will sound when an alarm condition is indicated. It can be fitted at a convenient location. An Alarm Mute push button is fitted on the panel to silence the siren.
- A set of volt free contacts for common alarm change over in the event of an alarm condition. These are for connection to an existing alarm system. These contacts remain in the “alarm” state until the control system is reset.
- A set of volt free contacts to indicate genset running condition. These are for connection to an existing status indication system. There are three terminals on the contacts, they can be wired normally open or normally closed and remain in the run state as long as the controller indicates the generator set is running

5.6.7 Automatic Preheat Control

If fitted glow plugs operate automatically prior to and during engine cranking. The automatic cranking sequence will be delayed by the preheating period.

5.6.8 Remote Annunciator Panels

Available on PowerWizard.

Remote Annunciator may be fitted to PowerWizard Panels (16 channel) .

6. OPERATION

6.1 Priming Procedure for 1100 Series

Warning:

- ⚠ Please wear appropriate Personal Protective Equipment (Section 2.2) before carrying out any of the following procedures as the operator will be in direct contact with diesel fuel. There will also be a risk of spillage.

Note:

- If unsure of your engine model please consult your local Dealer.
- Please see section 3.2 / 3.3 on where the fuel fill can be found on generator set

Following fuel filter servicing or draining of the low pressure fuel system for any reason, re-prime the fuel system as follows.

6.1.1 Products fitted with the small Perkins pre-filter / water separator

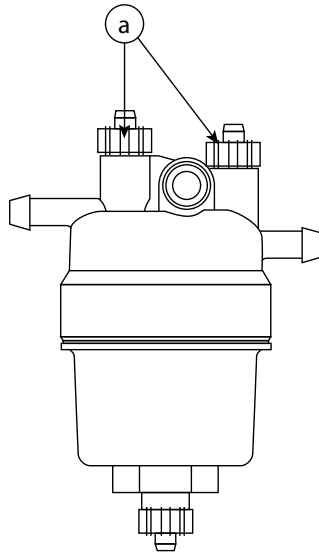

Figure 6.1 – Example of pre-filter / water separator

Note:

- Do not open the vent screws (a) when the fuel system is being primed, as diesel fuel will be discharged.

With Fuel Supply from the Base Tank

- Operate the priming switch for the standard pre-set 2 minute priming cycle (See section 5.3.10).
- Start engine.
- In the event of a failure to start the engine within 3 crank cycles, see the “Troubleshooting” section of this procedure for the repeat prime procedure.

With Fuel Supply from a Remote Tank

- Ensure fuel lines from the remote tank are full of fuel, the pump should never be run when bulk tanks are empty or when valves on the fuel fill lines are closed.
- With the fuel supply switched to remote tank, carry out the priming procedure.

The PowerWizard control panel can be used to energise the fuel lift pump in order to prime the engine as follows:

1. In order to prime the generator set:
MAIN MENU > CONTROL > ENGINE FUEL PRIMING.
2. To prime the set press the right cursor key, this will initiate a 2 minute priming cycle.
3. To exit the priming cycle press the left cursor key.

Note:

- The generator set may only be primed when the generator set is stopped and there are no active or present shutdown conditions.

6.1.2 Perkins 1506, 2206, 2506, 2806 Engines fitted with pre-filter / water separator

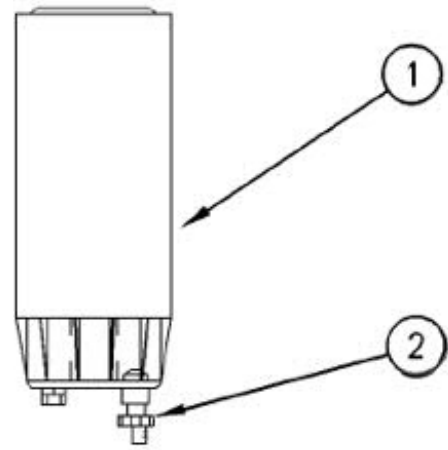
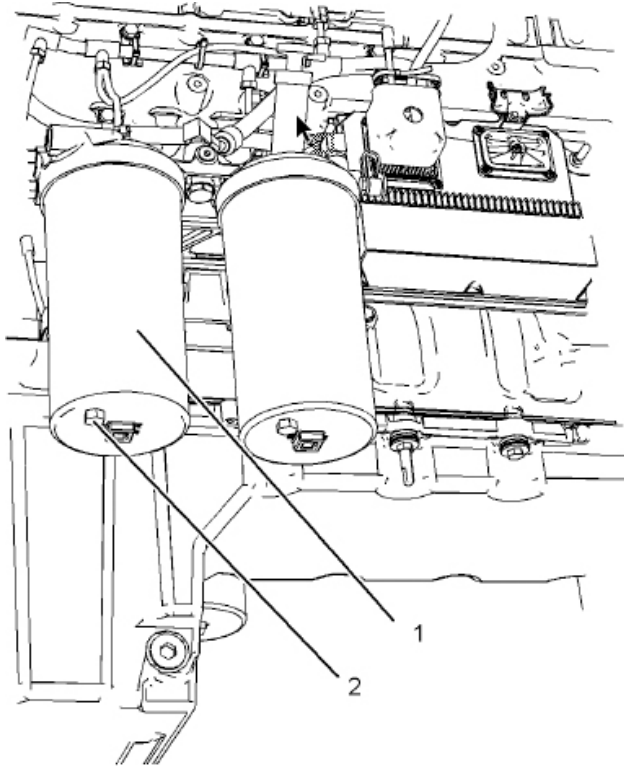

1. Pre-Filter/Water separator
2. Drain valve (2)

Example of pre-filter /water separators

NOTE

- The water separator is under suction during normal engine operation. Ensure that the drain valve is tightened securely to help prevent air from entering the fuel system.

Water separator bowl should be drained each week

1. Open drain valve(2). The drain valve is a self ventilated drain valve. Catch the draining water in a suitable container. Dispose of the water properly.
2. Close drain valve(2).

6.1.3 Products fitted with the Racor Pre-Filter / Water Separator (Option)

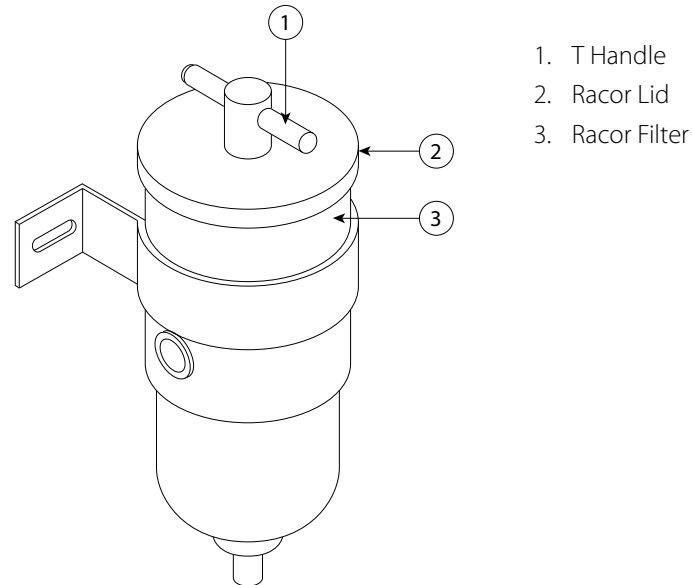

Figure 6.2 – Example of a Racor

With Fuel Supply from the Base Tank

Following Racor element change or if the Racor unit is drained for any reason, then repriming of the unit, as specified by Racor, will be required:

- Remove T-handle (1) and lid from the top of the unit.
- Screw T-handle into centre tube finger tight.
- Fill the assembly with clean fuel to just above the top of the element. This ensures the “dirty” side of the unit is completely filled with fuel.
- Lubricate the lid gasket (2) and T-handle (1) o-ring with clean fuel.
- Replace the lid (2) taking care to seat the gasket correctly and tighten the T-handle (1) – do not use tools.
- Operate the priming switch (if fitted) to give the system a 2 minute prime.
- Start engine.
- In the event of a failure to start the engine within 3 crank cycles, see the “troubleshooting” section of this procedure for the repeat prime procedure.

With Fuel Supply from a Remote Tank

If the fuel lines from the remote tank are empty:

- Carry out the manual filling procedure of the Racor unit as detailed above.
- Operate the priming switch for 2 minutes.
- Re-fill the Racor unit as detailed above.
- Re-prime for a further 2 minutes.
- Start engine.
- In the event of a failure to start the engine after 3 crank cycles, see the ‘troubleshooting’ section of this procedure for the repeat prime procedure.

If the fuel lines from the remote tank are full:

- Carry out the priming procedure as detailed in fuel supply from base tank.

6.1.3 Troubleshooting

Having completed the designated priming procedure, if the engine does not start, there may be air in the Pressure Regulator Valve (PRV) return loop hose.

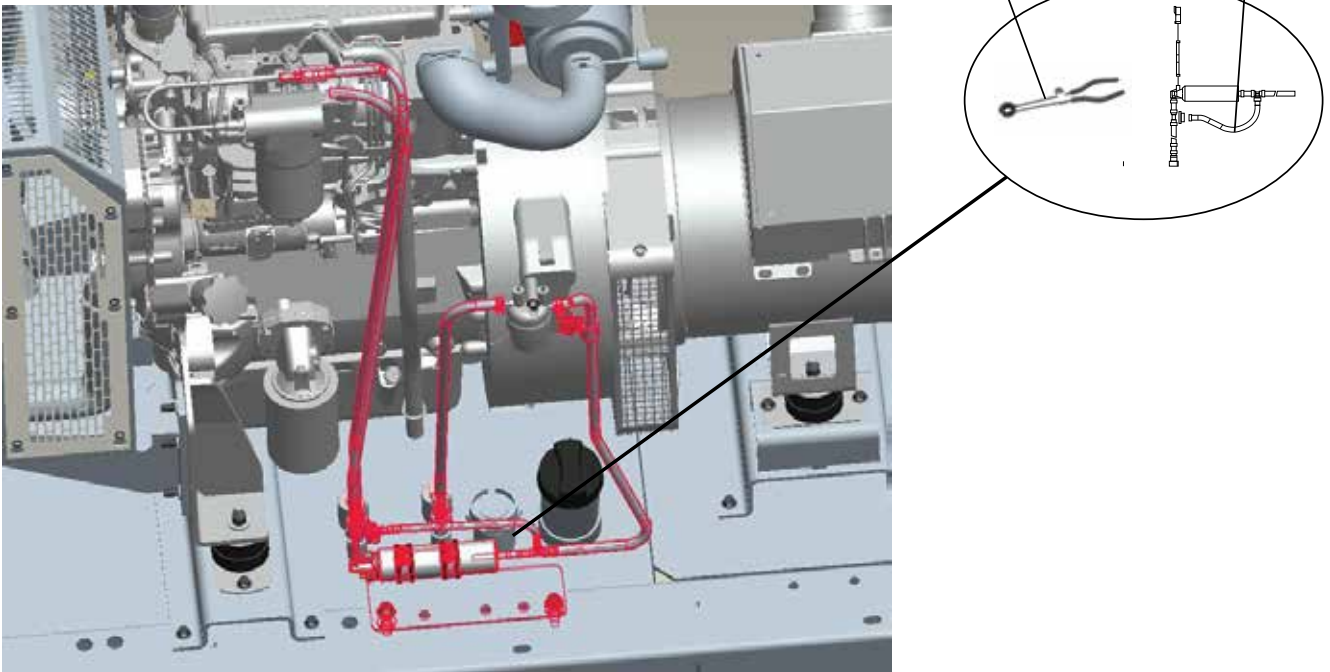

Figure 6.3 – Tooling (Not supplied) & Pressure Regulator Valve (PRV) return loop hose

1. Close the PRV return loop hose (B). Use Tooling (A) in order to close the PRV return loop hose (B). A typical example of Tooling (A) is shown in the illustration.
2. Repeat the priming procedure that is applicable to the configuration of the fuel system.
3. Release Tooling (A).
4. Start engine. Allow engine to run until smooth operation has been ensured and the pump is free from air.

6.1.4 Starting with Jump Start Cables

WARNING

- ⚠ **Improper jump start cable connections can cause an explosion resulting in personal injury.**
- ⚠ **Prevent sparks near the batteries. Sparks could cause vapors to explode. Do not allow jump start cable ends to contact each other or the engine.**

If the installation is not equipped with a backup battery system, it may be necessary to start the engine from an external electrical source.

After jump starting, the alternator may not be able to fully recharge batteries that are severely discharged. The batteries must be charged to the proper voltage with a battery charger.

Use a battery that is sourced with the same voltage as the electric starting motor. Use ONLY equal voltage for jump starting. The use of higher voltage will damage the electrical system.

Ensure that the main power switch is in the OFF position before jump start cables are attached to the engine that is being started.

1. Turn the start switch on the stalled engine to the OFF position. Turn off all accessories.
2. Connect one positive end of the jump start cable to the positive cable terminal of the discharged battery. Connect the other positive end of the jump start cable to the positive cable terminal of the charging or starting source.
3. Connect one negative end of the jump start cable to the negative cable terminal of the charging or starting source. Connect the other negative end of the jump start cable to the stalled engine block or to the chassis ground. This procedure helps to prevent potential sparks from igniting combustible gases that are produced by some batteries.
4. Charge the batteries. The engine will not continue to run after starting if the batteries have not been charged.
5. Start the engine.
6. Immediately after the stalled engine is started, disconnect the jump start cables in reverse order.

Consult your local Dealer for more information.

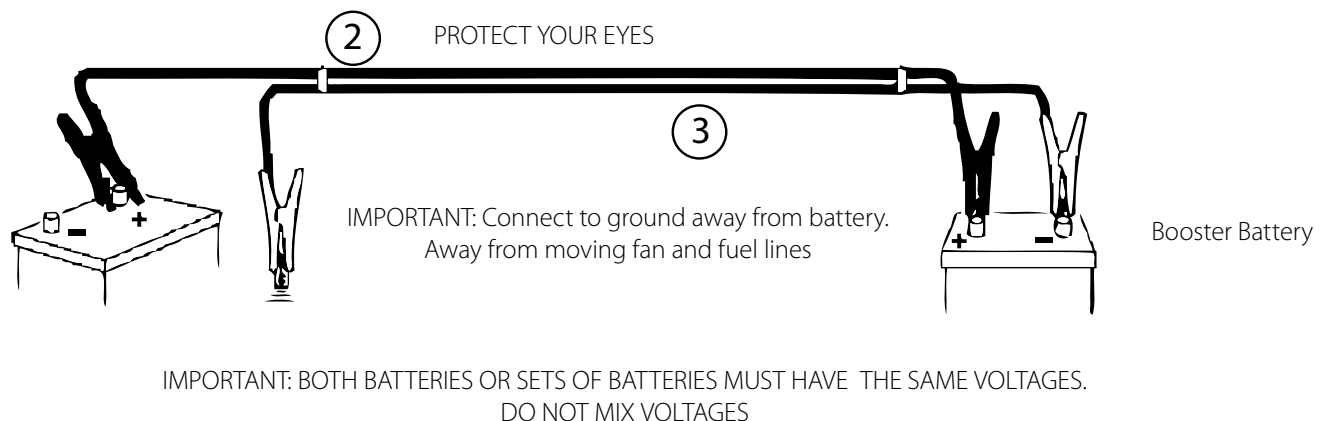

Figure 6.4 - Starting using jump start cables

6.2 Fuel Conservation

The efficiency of the engine can affect the fuel economy. The design and technology in manufacturing provides maximum fuel efficiency in all applications. Always ensure that genuine filters are used. Follow the recommended procedures to attain optimum performance for the life of the engine.

- Avoid spilling fuel.
- Fuel expands when the fuel is warmed up. The fuel may overflow from the fuel tank. Inspect fuel lines for leaks. Repair the fuel lines, as needed.
- Be aware of the properties of the different fuels. Use only the recommended fuels.
- Observe the service indicator frequently. Keep the air cleaner elements clean.
- Ensure that the turbocharger is operating correctly so that the proper air/fuel ratio is maintained. Clean exhaust indicates proper functioning.
- Maintain a good electrical system.
- One faulty battery cell will overwork the alternator and can consume excess power and excess fuel.
- Ensure that the belts are properly adjusted. The belts should be in good condition.

- Ensure that all the connections of the hoses are tight. The connections should not leak.
- Ensure that the driven equipment is in good working order.
- Cold engines consume excess fuel. Utilise heat from the jacket water system and the exhaust system, when possible. Keep cooling system components clean and keep cooling system components in good repair. Never operate the engine without water temperature regulators. All these items will help maintain operating temperatures.

Consult your local Dealer for more information.

6.3 Cold Weather Operation

FG Wilson Diesel generator sets can operate effectively in cold weather, however the starting and the operation of the diesel engine can be impacted by the following factors:

- The type of fuel that is used
- The viscosity of the engine oil
- The operation of the glow plugs
- Optional Cold starting aid
- Battery condition

The operation and maintenance of an engine in freezing temperatures is complex because of the following conditions:

- Weather conditions
- Engine applications

Recommendations from your FG Wilson dealer are based on past proven practices. The information that is contained in this section provides guidelines for cold-weather operation.

6.3.1 Hints for Cold Weather Operation

- Generator set operating temperatures -10°C to 50°C (14°F to 122°F). For operating conditions lower than -10°C (14°F), consult your local FG Wilson dealer.
- If the engine will start, operate the engine until a minimum operating temperature of 80°C (176°F) is achieved. Achieving operating temperature will help prevent the intake valves and exhaust valves from sticking.
- The cooling system and the lubrication system for the engine do not lose heat immediately upon shutdown. Retention of heat means that an engine can be shut down for a time and the engine can remain able to start readily.
- Install the correct specification of engine lubricant before the beginning of cold weather.
- Check all rubber parts (hoses, fan drive belts, and so on) weekly.
- Check all electrical wiring and connections for any fraying or damaged insulation.
- Keep all batteries fully charged and warm.
- Fill the fuel tank at the end of each shift.
- Drain the water from the fuel system. Refer to this Operation and Maintenance Manual, "Fuel System Primary Filter/Water Separator - Drain".
- Check the air cleaners and the air intake daily. Check the air intake more often when you operate in snow.

⚠ Personal injury or property damage can result from alcohol or starting fluids. Alcohol or starting fluids are highly flammable and toxic and if improperly stored could result in injury or property damage.

⚠ Do not use aerosol types of starting aids such as ether. Such use could result in an explosion and personal injury.

6.3.2 Viscosity of the Engine Lubrication Oil

Correct engine oil viscosity is essential. Oil viscosity affects the amount of torque that is needed to crank the engine. Consult your local Dealership for further information for the recommended viscosity of oil.

6.3.3 Recommendations for the Coolant

Provide cooling system protection for the lowest expected outside temperature. In cold weather, check the coolant often for the correct glycol concentration to ensure adequate freeze protection. Consult your local Dealership for further information.

7. LOAD TRANSFER PANELS

When the generator set is required to automatically provide switching to standby power in the event of mains failure, an optional load transfer panel is required. These transfer panels are designed to sense when the mains have failed, signal the generator set to start, switch the load from the failed mains to the generator set and then switch it back after the mains supply is re-established.

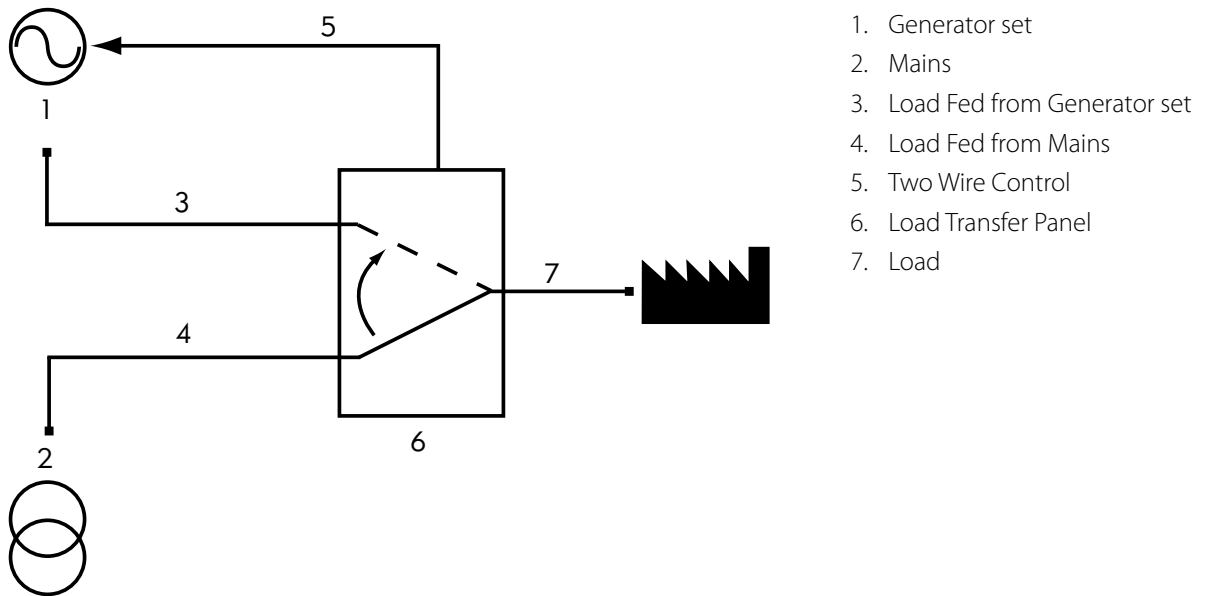

Figure 7.1 – Function of a Load Transfer Panel

There are two models of Load Transfer Panels available: The CTI and the ATI Series Intelligent Transfer Panels. The User Guide for these panels will be included in this manual, if chosen at time of order. Consult your local Dealership for further information.



Figure 7.2 – CTI and ATI Series Intelligent Transfer Panels

7.1 Engine Interface Module Description (where fitted)

The Engine Interface Module is a sealed, engine mounted module that provides switching relays for the Starter Motor Solenoid, Glow Plug and Fuel Solenoid. Each of these circuits is protected with individual fuses mounted in the module. Individual LED's illuminate when each circuit is energised.

There are two versions of the Engine Interface Module available:

EIM Basic: The EIM is utilised in conjunction with control panels equipped with overspeed shutdown.

EIM Plus: The EIM plus is used in conjunction with control panels not equipped with overspeed shutdown.

Overspeed Signal (EIM Plus only): The EIM Plus monitors the speed signal from the magnetic pick-up. If the engine speed rises above a certain pre-settable value, the module sends a zero volt signal to the generator set control panel to activate the Overspeed Fault circuitry.

The Overspeed Set Point is factory set at 55 Hz for 50 Hz sets and 66 Hz for 60 Hz sets. This can be adjusted using the adjustment screw accessed through the hole beside the Overspeed Set-up LED. While the engine is running at the rated speed (1500 rpm for 50 Hz or 1800 rpm for 60 Hz) the adjustment screw should be adjusted until the Overspeed Set-up LED just goes out. This sets the overspeed value at 10% above the speed at which the generator set is operating.

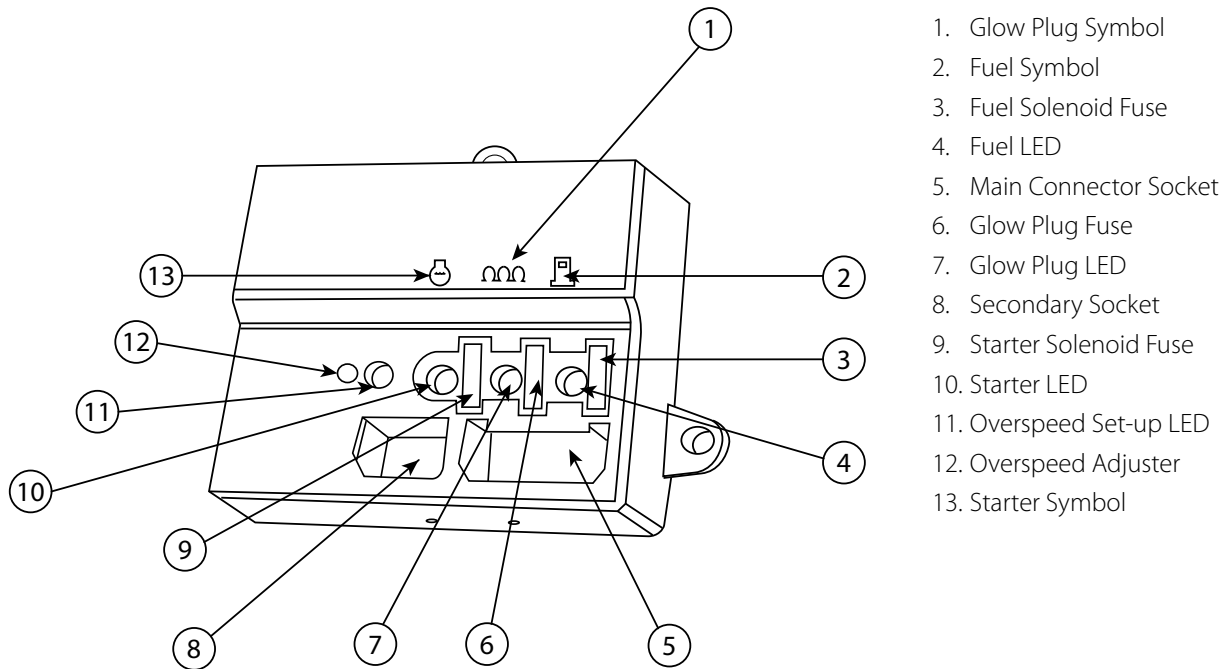

Figure 7.3 – Engine Interface Module (EIM)

7.2 Output Circuit Breaker Description

The alternator output circuit breaker is of sufficient rating for the generator set output. Electrical output is switchable through this device, with "ON" being indicated by the handle being up. The breaker will carry its rated current continuously but will trip to off position if the rating on any one phase is exceeded for a period depending on the percentage overload and the circuit breaker characteristics.

Warning

⚠ Maintenance and/or replacement of circuit breakers should only be completed by a fully trained technician.

8. ELECTRONIC ENGINE FAULT DETECTION FLASH CODES

Perkins 1306–E87 electronic engines automatically record engine faults in the Electronic Control Module (ECM) to assist the engineer in troubleshooting. The fault codes can be read using the red and amber lamps situated on the top of the relay box, as shown in the picture below.

1. Relay Box – This interfaces between the Electronic Control Module (ECM) and the control panel.
2. Amber Light – If lit indicates an active fault. Please contact your local Dealership for assistance. The generator set may continue to run but may be on reduced power.
3. Red Light – Used for flash code reading, this will not light in normal operation.
4. Push Buttons – Push buttons 1 & 0 are used for fault code reading only.
5. Diagnostic Plug – This is used for communication with a laptop / PC. This should only be used by an authorised technician. Please consult your local Dealership.

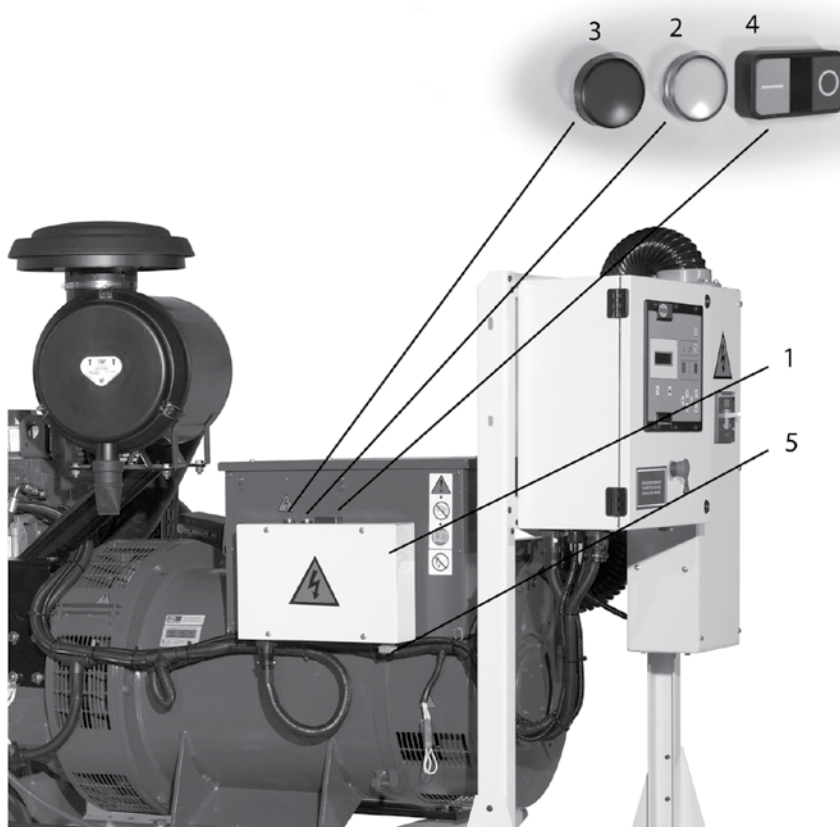

Figure 8.1 – 1306-E87 Electronic Engines Relay Box

Note:

- The engine protection systems e.g. low oil pressure, high coolant temperature, are within the control of the generator set control panel. These sensors will shut the engine down before the ECM sensors.

9. MAINTENANCE

Warning:

⚠ **The following procedures should only be carried out by a qualified technician.**

A good maintenance programme is the key to long generator set life. Maintenance and service should only be carried out by qualified technicians. Records of this work should be kept to aid in developing an efficient maintenance programme.

In general, the generator set should be kept clean. Do not permit liquids such as fuel or oil film to accumulate on any internal or external surfaces or on, under or around any acoustic material, if fitted. Wipe down surfaces using an aqueous industrial cleaner. Do not use flammable solvents for cleaning purposes.

Any acoustic material with a protective covering that has been torn or punctured should be replaced immediately to prevent accumulation of liquids or oil film within the material.

Refer to a qualified generator set technician for details of required preventative maintenance.

9.1 Battery Maintenance

Warning:

- ⚠ **Ensure personnel have been trained in the handling and proper use of batteries. Always wear the correct personal protection equipment (PPE) when handling batteries.**
- ⚠ **Battery maintenance checks should also be completed as part of your routine maintenance inspections.**
- ⚠ **Always wear the appropriate PPE when handling electrolyte. If splashed with electrolyte, immediately flush the affected area with clean water and seek medical advice.**
- ⚠ **Never add undiluted sulphuric acid to a battery.**
- ⚠ **Keep batteries upright to prevent electrolyte spillage. Electrolyte is a dilute sulphuric acid and is harmful to the skin.**
- ⚠ **Use tools with insulated handles when removing or fitting the battery. Never place tools or metal objects across the battery terminals.**
- ⚠ **During charging, the battery gives off explosive gases. Keep the battery in a well ventilated area and away from naked flames and sparks. Smoking is also prohibited.**

Generator set batteries, by law, must not be disposed of with household waste.

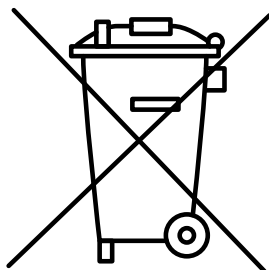

Batteries contain hazardous materials and in the charged state, each cell contains electrodes of lead metal (Pb) and lead (IV) dioxide (PbO₂) in an electrolyte of about 33.5% w/w (6 Molar) sulphuric acid (H₂SO₄). In the discharged state both electrodes turn into lead (II) sulphate (PbSO₄) and the electrolyte loses its dissolved sulphuric acid and becomes primarily water.

It can be damaging to the environment to send these to landfill, burning batteries can also cause atmospheric pollution.

Dealing with lead acid batteries can be hazardous so it is important to follow all safety guidelines.

Batteries are an essential part of the generator set and should be maintained appropriately. Keep the battery area clean and dry and ensure any vent caps are tight (if fitted).

Clean the battery case with one of the following cleaning solutions:

- A mixture of 0.1 kg (0.2 lb) of baking soda and 1 L (1 qt) of clean water
- A mixture of 0.1 L (0.11 qt) of ammonia and 1 L (1 qt) of clean water

Thoroughly rinse the battery case with clean water.

All battery connections must be kept clean and tight. Use a fine grade of sandpaper to clean the terminals and the cable clamps. Clean the items until the surfaces are bright or shiny. Do not remove material excessively. Excessive removal of material can cause a poor connection between the clamps and the battery terminals. Coat the clamps and terminals with grease or other terminal protector to prevent corrosion.

The electrolyte level should be covering the plates/grids (1/2 inch / 13 mm) within the battery to maximize full charge transfer. If the liquid level is below the plates/grids, only add distilled water; never add battery acid to top up the volume, as the addition of extra acid will destroy the grids.

It is recommended to check the electrolyte and condition of the batteries every 500 running hours. In high ambient conditions, it is recommended to use thermal compensation and check electrolyte levels more frequently, for example every 200 running hours. These checks should also be completed as part of your routine maintenance inspections.

9.1.1 Battery Removal and Fitting

- Battery acid can burn clothing and skin or cause blindness if it leaks. Please wear protective clothing when inspecting a battery prior to its disconnection / transportation.
- Ensure the battery to be fitted is filled with the correct levels and mixture of electrolyte and is fully charged.
- If vents are fitted, ensure they are firmly in place.
- Before removing a battery, carry out a thorough inspection of its condition. Use a torch if visibility is poor to check all sides of the battery for any marks, dents or leaks.
- If the battery has any severe dents or leaks please contact your local Dealer for assistance. DO NOT attempt to remove the battery.
- Disconnect the battery safely before inspecting it (see below).
- Disconnect any battery charging circuitry before fitting the battery.
- When removing a battery for whatever reason always ensure all load is removed before disconnecting the battery so that no sparks are created. Disconnect the negative cable first followed by the positive cable to avoid short circuit against any metal framework, then remove the hold down clamp or strap securing the battery base. The battery can be heavy so please be careful when lifting and carrying the battery. Seek assistance if required.
- When refitting the battery, ensure the terminal posts are correctly aligned with the cables to avoid wrong connection and place the new battery into the hold-down tray and reattach the hold-down clamp or strap. Attach and tighten the positive battery cable to the positive terminal first. Then attach and tighten the negative battery cable to the negative terminal.
- Keep the battery terminals clean and free from corrosion and lightly smear the connections with petroleum jelly.
- Ensure battery terminals are tight as loose battery terminals can reduce battery life and are a fire hazard.
- Ensure the positive terminal on each battery is covered correctly.
- When fitting a battery and / or battery charger please ensure they are appropriately matched. Please consult a qualified technician if unsure.
- During transport, please ensure that battery terminals are covered to remove the possibility of a short circuit.
- Keep the battery upright at all times.

9.1.2 Battery Fluid Levels

⚠ If your battery has a fluid leak or a cracked case please consult your local Dealer about replacing the battery.

To ensure the battery operates at its optimal level it is advised that you check the fluid levels as outlined in section 9.1 above.

Low Fluid Levels

The electrolyte fluid level is too low if any part of the plates are exposed to air. If the plates are not fully covered with electrolyte, then the battery cannot operate at full capacity. Exposing the plates to air can destroy the area exposed within a few days reducing the performance of your battery. If the electrolyte is only about 1/2 inch (13 mm) below the top of the plates adding distilled water to the battery may return it to serviceable condition at a slightly reduced capacity. Please consult your local Dealer about the performance and replacement of your battery.

Recommended Fluid Levels

The recommended fluid level is approximately 1/2 inch (13 mm) above the top of the plates or about 1/8 inch (3 mm) below the bottom of the filler tubes that extend down from the port openings. If the fluid level is within these recommended guidelines, replace the port covers and inspect again in three months.

Maximum Fluid Levels

The maximum safe fluid level is when the fluid is just touching the bottom of the filler tubes that extend down from the port openings. When the fluid level reaches the bottom of a filler tube, a distinctive eye shape meniscus should appear indicating that the battery has reached its maximum level and you should stop filling the battery.

9.2 Preventative Maintenance Interval Schedule

Depending on the application of the generator set, requirement for preventative maintenance will vary.

Warning:

- ⚠ **Enclosures fitted with doors stays or lift off doors (when Applicable) should not be used when wind exceeds 15 mph**
- ⚠ **Maintenance intervals for the engine may be more frequent than those shown in this section. Please consult your local dealer for maintenance guidelines specific to your engine**
- ⚠ **Operators should only perform the Pre-Start Check tasks detailed in the Control System Description – Section 5.**
- ⚠ **The following procedures should only be carried out by a qualified technician.**

Daily or at Each Startup:

(For standby generator sets these procedures may be performed weekly.) A walk around inspection should be performed on a daily basis and prior to starting the engine. The Pre-Start checks contained in Section 5 should be performed during this walk around.

Every Two Weeks:

(For standby generator sets that have not been run.) Perform an operational check on the generator set by starting and running it for only 5 minutes.

Every Month:

(For standby generator sets that have not been run on load.) Perform an operational and load check on the generator set by starting and running the generator set on at least 50% load for 1 to 2 hours.

Drain the Water and the Sediment from Fuel tank – Fuel tanks can be drained from the bottom of the fuel tank by the drain plug or drain valve (if applicable) or by using a hand pump accessible through the fuel fill pipe or tank access socket. Dispose of the water properly.

Drain dual wall tank bund area – Dual wall tanks (if applicable), outer bund area should be drained by a hand pump accessible through the rear access socket located behind the generator, dispose of any removed fluid properly.

Warning:

- ⚠ **Do not run diesel engines at low loads for long periods.**

Every Twelve Months or 500 Hours:

Repeat the daily procedures plus the following:

1. Check all control system safety devices by electrically simulating faults.
2. Clean all battery cap vents.
3. Tighten all exhaust connections.
4. Tighten all electrical connections.
5. Start the engine and observe the instrument panel to ensure that all gauges and meters are operating properly.

9.3 Alternator Preventative Maintenance

There is no routine maintenance required on the alternator, however observe the following recommendations:

- Periodically inspect the alternator winding condition and carry out general cleaning.
- Periodically inspect the cable connections between the alternator and the circuit breaker.
- See your local Dealer.

9.4 Engine Preventative Maintenance

Please consult your local dealer for guidance on specific maintenance requirements for the following:

- Daily start up checks
- Weekly
- Service schedules – should only be completed by a qualified technicians

9.5 Welding on or near Generator Sets

When welding is being performed near or on Generator Sets, without precautions and correct procedures, the electrical/electronic and other components could be severely damaged by the current flow from the welder.

If the engine is electronic, due to the complexity and type of components within the engine ECM, this could be severely damaged.

Proper welding procedures are necessary in order to avoid damage to the engine ECM, sensors, and associated components. When possible, remove the component that requires welding from the unit and then weld the component. If removal of the component is not possible, the correct procedure must be followed.

When welding on a unit that is equipped with an Electronic Engine, the following is considered to be the safest procedure.

Warning:

- ⚠ Do not ground the welder to electrical components such as the ECM or sensors. Improper grounding can cause damage to the drive train, the bearings, hydraulic components, electrical components, and other components.**
 - ⚠ Do not ground the welder across the centerline of the package. Improper grounding could cause damage to the bearings, the crankshaft, the rotor shaft, and other components.**
 - ⚠ Clamp the ground cable from the welder to the component that will be welded. Place the clamp as close as possible to the weld. This will help reduce the possibility of damage.**
 - ⚠ Perform the welding in areas that are free from explosive hazards.**
1. Stop the engine. Turn the switched power to the OFF position.
 2. Disconnect the battery cables from the battery. If a battery disconnect switch is provided, open the switch. If possible, remove the battery completely.
 3. Disconnect the connectors from the ECM. Move the harness to a position that will not allow the harness to move back accidentally and contact any of the ECM pins.

9.6 Decommissioning, Dismantling and Disposal

Please consult your local Dealer and local regulations regarding the disposal of materials on your generator set

Most of the Iron, steel and copper from the generator set can be taken by companies specialising in recycling scrap metal

Some components such as electrical cable, electronic accessories and plastics require specialist treatment. Please consult a specialist company regarding the removal of such items

NOTES

NOTES